

Wireless Ceiling Mount Sensor

Lutron's occupancy and vacancy sensors are wireless ceiling-mounted battery-powered passive infrared (PIR) sensors that automatically control lights via RF communication to compatible dimming or switching devices. These sensors detect the heat from people moving within an area to determine when the space is occupied. The sensors then wirelessly transmit the appropriate commands to the associated dimming or switching devices to turn the lights on or off automatically. They combine both convenience and exceptional energy savings along with ease of installation.

Features

- Wireless occupancy sensor has 3 settings available: Auto-On/Auto-Off, Auto-On Low-Light/Auto-Off, and Manual-On/Auto-Off
- Auto-On Low-Light feature will only turn lights on automatically if there is less than approximately 1 fc (10 lux) of ambient light
- Vacancy model available to meet CA Title 24 requirements
- 10-year battery life design
- Passive infrared motion detection with exclusive Lutron XCT™ Technology for fine motion detection
- 360° coverage ranges from 324 sq. ft to 676 sq. ft. for superior fine motion detection
- Multiple ceiling-mount methods available for different ceiling materials
- RoHS compliant
- Simple and intuitive adjustments available for Timeout, Auto-On, and Sensitivity settings
- Front accessible test buttons make setup easy
- Lens illuminates during test mode to verify ideal locations
- Up to 3 sensors can be added with each RF dimming or switching device for extended coverage
- Each sensor may be added to up to 10 compatible RF dimming and switching devices for spaces with multiple zones of lighting

Models Available:

- LRF2-OCR-B-P-WH 434 MHz Occupancy/Vacancy Sensor
- LRF2-VCR-B-P-WH 434 MHz Vacancy Sensor



Compatible RF Devices:

Communicates to the following wireless Lutron systems:

Maestro® Wireless (MRF2)

RadioRA®2

GRAFIK Eye® QS Wireless

Job Name:	Model Numbers:
Job Number:	

Specifications

Standards

- FCC · IC
- Meets CA Title 24 requirements

Environment

- Temperature: 32 °F - 104 °F (0 °C - 40 °C)
- For indoor use only

Power

- Operating voltage: 3 V_{DC}
- Operating current: 20 µA nominal
- Requires two CR 123 lithium batteries
- 10-year battery life design
- Non-volatile memory (saved changes are stored during power loss)

Sensor Coverage Test

- Front accessible test button
- Lens illuminates orange in response to motion during test mode and is visible from 30 ft (9.1 m)

Wireless Communication Test

- Front accessible test buttons
- Turn loads on and off

Timeout Options

- 5 minutes
- 15 minutes *
- 30 minutes

Auto-On Options (Occupancy Version Only)

- "Always" * - Sensor turns lights ON and OFF automatically.
- "Low light" - Sensor turns lights ON automatically only in low ambient light conditions. Sensor turns lights OFF automatically.
- "Disable" - Lights must be turned ON manually from dimming or switching device. Sensor turns lights OFF automatically.

Sensitivity Options

- Low Activity *
- Medium Activity
- High Activity

* - default settings

Dimensions

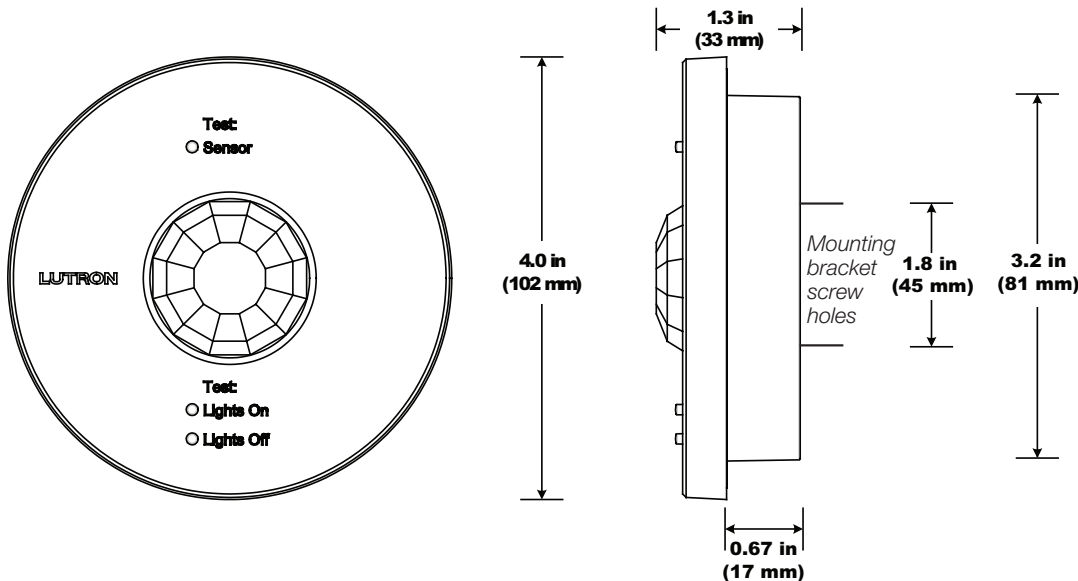

Job Name:	Model Numbers:
Job Number:	

Range Diagrams

Sensor Coverage with an 8 ft (2.4 m) Ceiling

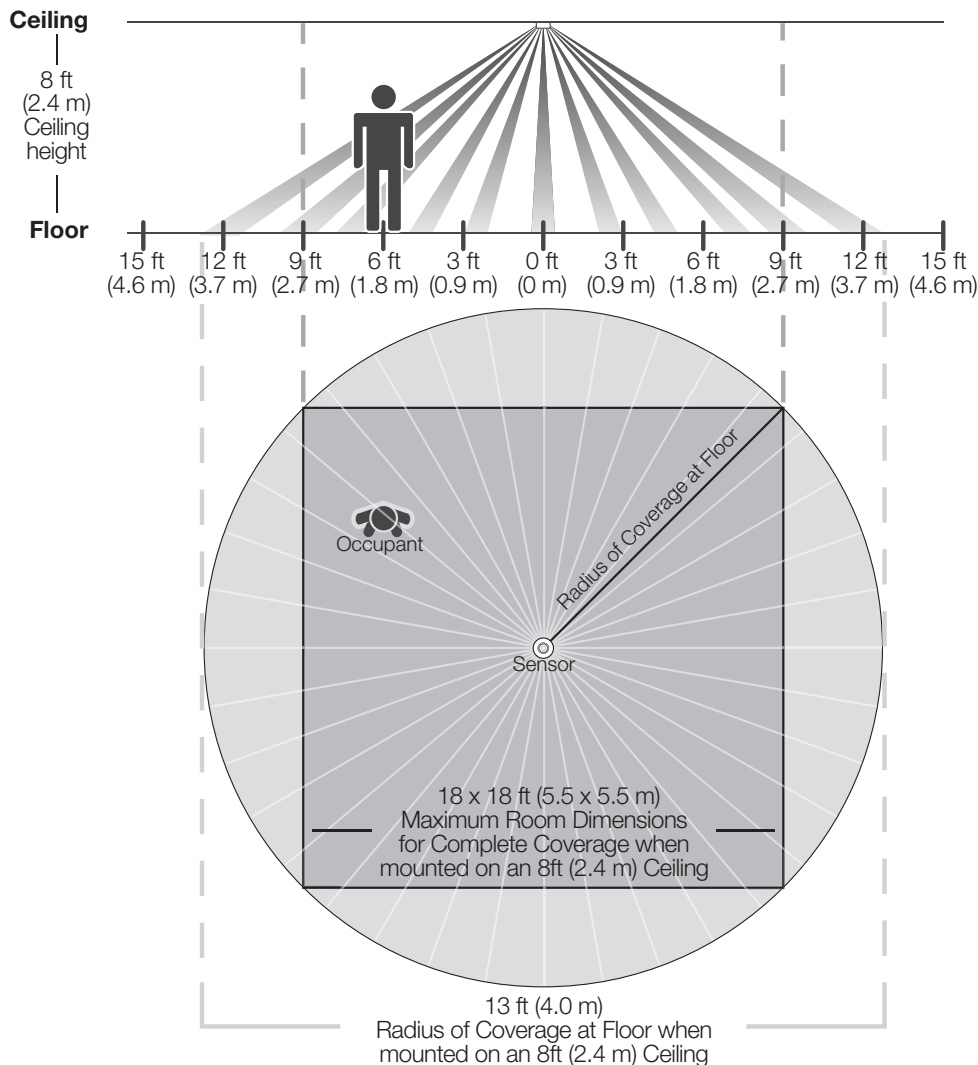

Sensor Coverage Chart

Ceiling Height	Max. Room Dimensions for Complete Coverage	Radius of Coverage at Floor
8 ft (2.4 m)	18 x 18 ft (5.5 x 5.5 m)	13 ft (4.0 m)
9 ft (2.7 m)	20 x 20 ft (6.1 x 6.1 m)	14.5 ft (4.4 m)
10 ft (3.0 m)	22 x 22 ft (6.7 x 6.7 m)	16 ft (4.9 m)
12 ft (3.7 m)	26 x 26 ft (7.9 x 7.9 m)	19 ft (5.8 m)

* Add up to three sensors to one receiving device for maximum coverage.

Job Name:	Model Numbers:
Job Number:	

Installation Overview

Sensor Placement

- The sensor’s ability to detect motion requires line-of-sight of room occupants. The sensor must have an unobstructed view of the room. **DO NOT** mount behind or near tall cabinets, shelves, hanging fixtures, ceiling fans, etc. The sensor cannot see through glass objects such as patio or shower doors.
- Hot objects and moving air currents can affect the sensor’s performance. To ensure proper operation, the sensor should be mounted at least 4 ft (1.2 m) away from light bulbs below the ceiling line and HVAC vents.
- The sensor’s performance depends on a temperature differential between the ambient room temperature and that of room occupants. Warmer rooms may reduce the sensor’s ability to detect occupants.
- The sensor should be mounted within 60 ft (18 m) line of sight or 30 ft (9.1 m) through walls, of the associated dimming and switching receiving devices.

Set Up Sensor with Receiving Device

GRAFIK Eye® QS Wireless, RadioRA-SR

- Press and hold “Lights On” and “Lights Off” buttons on sensor simultaneously for 3 seconds to enter setup
- Press and hold on/off button on receiving device for 3-6 seconds
- Load will flash 3 times upon successful association
- Press and hold “Lights On” and “Lights Off” buttons simultaneously for 3 seconds to exit setup

Maestro Wireless®

- Press and hold on/off button on receiving device for 6 seconds
- Press and hold “Lights Off” button on sensor for 6 seconds
- Load will flash 3 times upon successful association

Advanced Set-Up (Adjusting Timeout, Auto-On, and Sensitivity)

Check Settings:

- Press and release desired button; LED indicates current setting

Change Settings:

- Press and hold desired button until LED blinks
- Press button again to select setting
- Press and hold button until LED turns solid to save setting

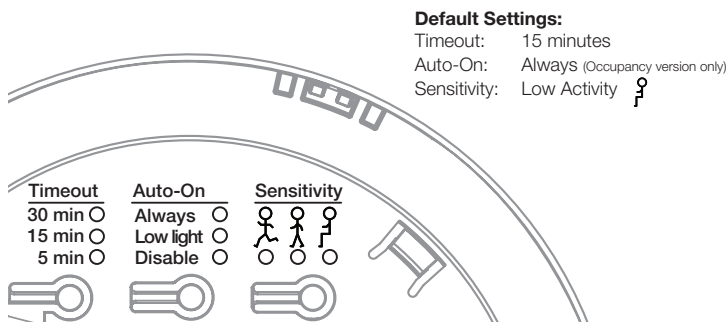

Job Name:	Model Numbers:
Job Number:	

Mounting

Temporary mounting is recommended to test sensor coverage and wireless communication before permanently installing the sensor.

Drop Ceiling (Compressed Fiber Ceiling Tile)

- The ceiling tile mounting wire is provided for both temporary and permanent mounting of the sensor to ceiling tiles. It is designed to allow temporary mounting, testing, and repositioning (if necessary) of the sensor without damaging a ceiling tile. Once the sensor's final position has been chosen, the mounting wire should be twisted to lock the sensor in place permanently.

Solid Ceiling (Drywall, Plaster, Concrete, or Wood)

- Temporary mounting: Two 3M™ Command™ adhesive strips are provided for temporarily mounting and testing the sensor. These strips are designed for easy, damage-free removal and are not reusable.
- Permanent mounting: Screws and anchors provided to mount sensor.

3M and Command are trademarks of 3M Company.

<p>Job Name:</p> <p>Job Number:</p>	<p>Model Numbers:</p>
--	-----------------------

Lens Masking

Whenever possible, the sensor should be installed in a location where it cannot easily see into areas outside the intended space, such as hallways or adjacent rooms. If this situation cannot be avoided, portions of the lens are masked with the provided labels to block the sensor's view of the undesired areas.

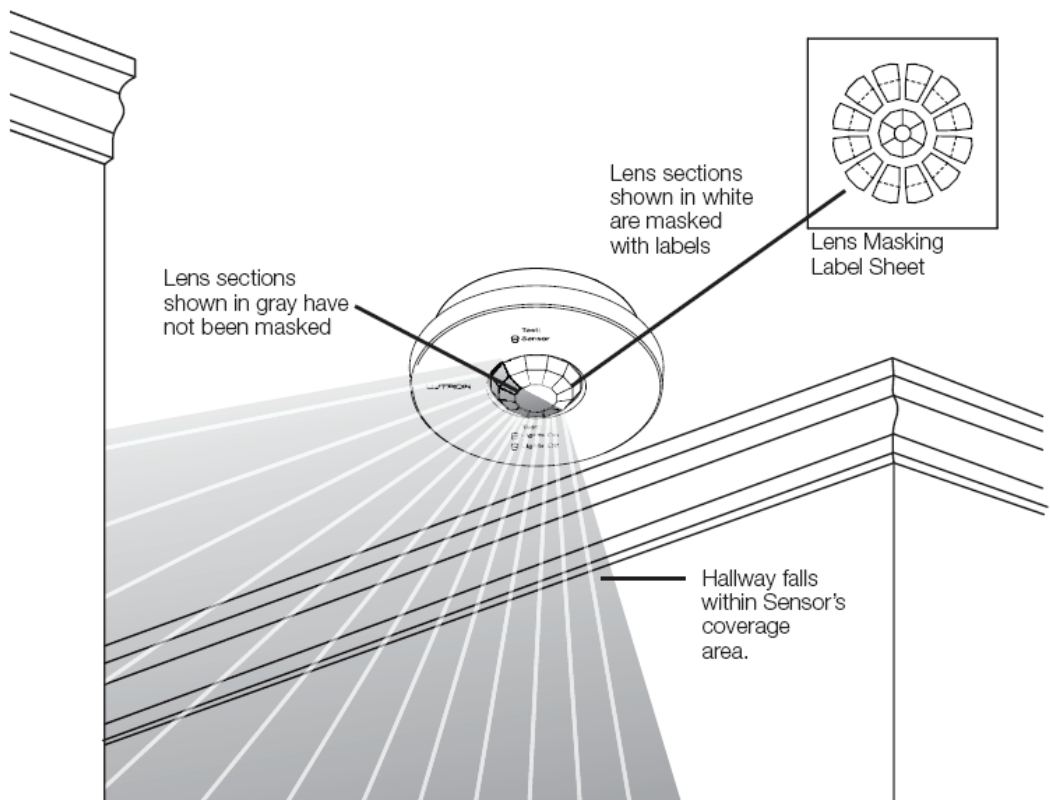

Job Name:	Model Numbers:
Job Number:	