

Metal Halide — Pulse Start vs. Probe Start

By Dick Erdmann
GE Specification Engineer

As we enter this new age of energy awareness, the lighting community has been at the forefront finding more and more ways to conserve energy. One of these ways is through the technology and construction of Metal Halide lamps, resulting in significant improvements to both energy savings and performance.

History

Before we review the operational characteristics, it is interesting to note the history behind this High Intensity Discharge (HID) light source. References to passing an electric arc through mercury gas to provide light goes back to the mid-19th century but around the turn of the century Peter Cooper Hewitt developed mercury filled tubes and in 1902 the Cooper Hewitt Vapor Lamp Company was established to make and market these lamps. Ultimately, these proved to be too cumbersome with heavy ballasts and as much as a pound of mercury. In 1919, GE purchased the Cooper Hewitt Vapor Lamp Co. In 1933, GE began marketing a new mercury lamp followed by the High Pressure Sodium lamp in 1961, the Quartz Metal Halide lamp in 1962 and the Ceramic Metal Halide lamp in the mid-1990s.

Multi Vapor® Arc Tube Evolution

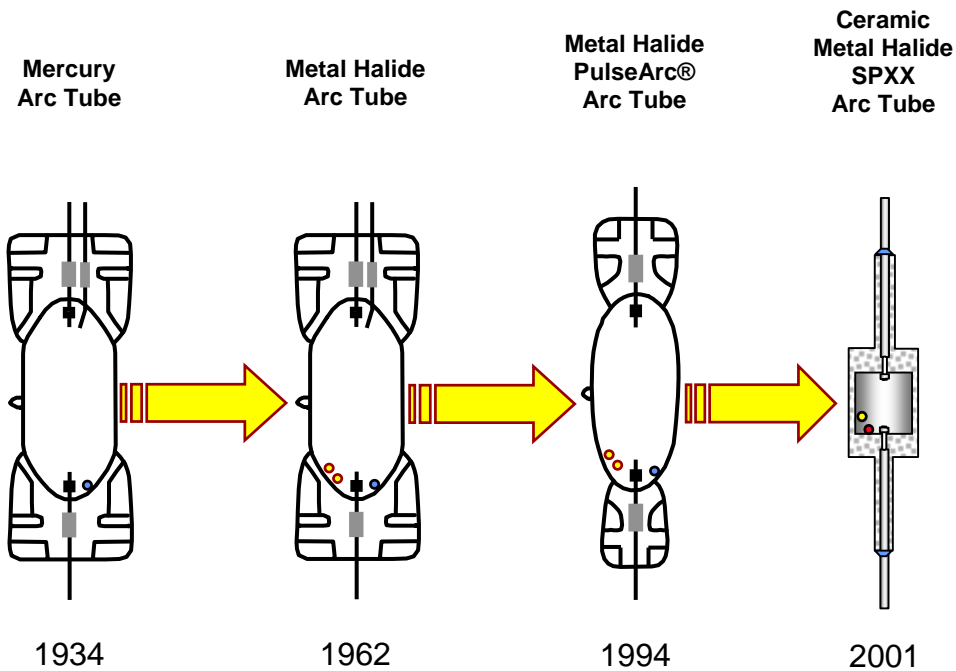

With the advent of each technology, new challenges were presented. Mercury lamps replaced incandescent in industrial and roadway applications and improved the economics by providing longer life and a more efficient light source. The downside was that the color quality was compromised to some degree. The invention of High Pressure Sodium (HPS) dramatically changed discharge lighting by providing much higher efficacy and life but still compromising color quality by having the golden white color. Then along came Metal Halide, and color quality was significantly improved but lamp life and efficacy were not quite as good as HPS. To come up with a lamp that gave good color, efficacy and life became the challenge of lamp designers. The technical community met the challenge and the Metal Halide lamp was invented. Many things have to be considered in designing a discharge lamp. Design areas that need to be considered include arc tube thermal profile, gas fill pressures, arc tube body shape, arc tube material, chemistry, electrode characteristics and ballast design all to name a few. Making a compromise in one area may have ramifications in other areas; thus, affecting lamp performance and/or cost.

Probe Start Metal Halide Construction

Standard “probe-start” Quartz Metal Halide lamps are electrically similar to mercury designs except that they require a higher starting voltage from the ballast. In order to provide this, the ballast has to have larger magnetic components, which have the effect of adding cost to the system and using more energy. An important element in the design of the arc tube is the fill pressure. Increasing the fill pressure results in better electrode performance, improved lumen maintenance and longer life but on the negative side, it makes starting the arc more difficult using a traditional magnetic ballast. Therefore, the designer has to make compromises by limiting the fill pressure to be able to start the arc while still providing good lamp performance. In a “Probe Start” lamp, a starter probe is installed near one of the main electrodes to help in gas ionization during the first few seconds of the starting cycle. After a short time, this starter probe is turned off using a bimetal switch within the lamp that functions with the heat generated within the arc tube.

PROBE START LAMP

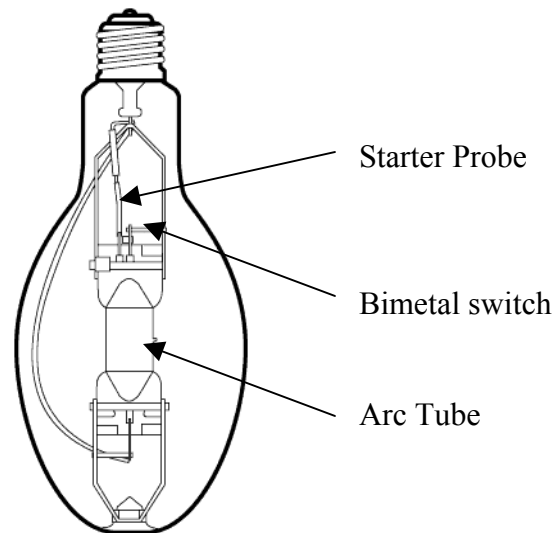

Pulse Start Metal Halide Construction

In the 1980s, metal halide lamps were typically 175 watts and lower but with technology and the use of electronics, lamp designers began to look into removing this starter probe and increasing the fill pressures. By coordinating designs of both lamp and ballasts, the lamp designer was able to remove the starter probe. The ballast designer then increased the starting voltage and provided a special electronic starting circuit which is often referred to as an “igniter” or “starting aide.”

PULSE START SYSTEM

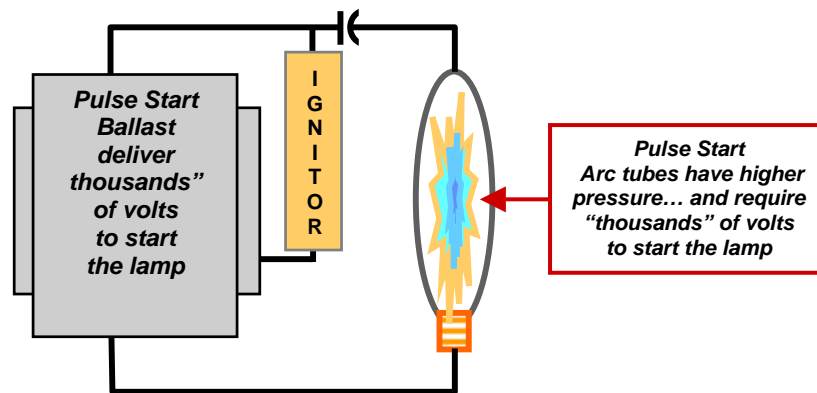

The removal of the starter probe and increased starting voltage allowed the arc tube designer to increase the arc tube fill pressure, all of which gave a significant improvement in lamp lumen maintenance and life. Thus, was born the “Pulse-Start” lamp. Eventually, this design would spill over to higher wattage lamps and today’s family of GE PulseArc® Metal Halide lamps range in wattage’s from 32 watts up to 1000 watts in both clear and coated lamps.

The addition of the electronic starting circuit has not only allowed for higher starting voltages to the arc tube but has also created the opportunity for ballast manufacturers to reduce the size of the ballasts. This reduced size translates into a magnetic ballast that is less costly to produce, cooler to operate and more energy efficient with fewer watts loss.

Pulse Start technology also provides many lamp benefits over traditional Probe Start technology. Some of these benefits include:

- Longer lamp life
- More lumens
- Higher efficacy (lumens per watt)
- Increased lumen maintenance
- Better cold starting capabilities (as low as -40° C)
- Faster warm-up times
- Faster starting
- Shorter restrike times
- Better lamp-to-lamp color variation.

Pulse Start Economic Advantages

Pulse Start lamp systems can yield fewer fixtures for a given system because of the increased lumen output and that means a lower capital cost for the system. Also, because the lamp life is longer than traditional Probe Start lamps and the lumen maintenance can extend the re-lamp interval, fewer lamps will be required over the life of the system. Fewer lamps also have the potential additional side benefit of reduced disposal or re-cycle cost, which is better for our environment and may have some economic benefit as well.

The following Lumen Maintenance chart is a good example of how various types of Metal Halide lamps compare. From this chart, it is clear that not only do Pulse Start lamps provide more lumens but also the choice of electronic vs. magnetic ballast makes a significant difference as well.

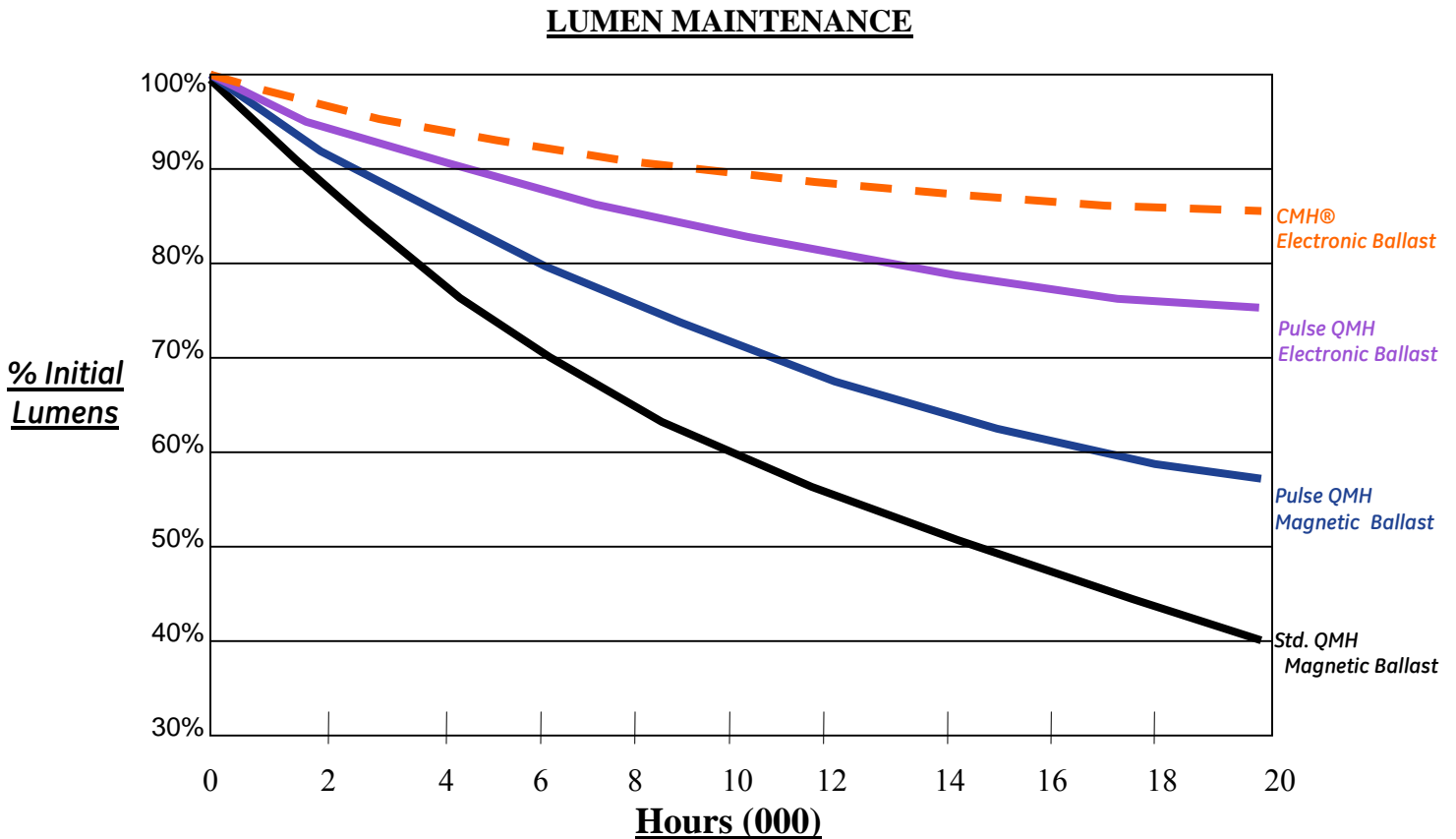

Legislation

In 2006, the California Energy Commission, in an effort to conserve energy and recognize the benefits of Pulse Start Metal Halide lamps, introduced into “California Title 20 Code of Regulations” wording banning luminaires with lamps in the vertical base up (VBU) position that had Probe Start ballasts in the 150-500 watt range. In 2008, that was extended to include lamps in all positions and added an efficiency clause for the

ballasts. Since that time, many states have adopted this or vary similar wording and added them to their state energy codes.

More recently, the 2007 Energy Bill, officially known as the “Energy Independence and Security Act of 2007,” was signed by President Bush, which will mandate on Jan. 1, 2009, for all states that Metal Halide fixtures designed to be operated with Metal Halide lamps from 150- to 500 watts shall contain:

- Pulse Start Metal Halide ballast with a minimum efficiency of 88%
- Magnetic Probe Start metal halide ballast with a minimum efficiency of 94%
- Non-Pulse Start electronic ballast with a minimum efficiency of 92% for wattages greater than 250 watts and 90% for wattages less than or equal to 250 watts.

Exceptions to this are:

- Fixtures with regulated lag ballasts
- Fixtures that use electronic ballasts that operates at 480 volts
- Fixtures that are rated for 150 watt lamps
- Fixtures that are rated for use in wet locations
- Fixtures that contain a ballast that is rated to operate at ambient air temperatures of 50° C.

This will essentially make most Probe Start fixtures a thing of the past, and one can expect that all new Metal Halide fixtures will be of the Pulse Start technology.