

RA™ 750

PORCH-LIFT®

VERTICAL PLATFORM LIFT

Unit Dimensional Drawing

STANDARD EQUIPMENT

Platform Control Switch with Emergency Stop, Key Operation
 All Controls – constant pressure
 Low Voltage Controls – 24 Volt
 Platform Safety Pan
 36" high Platform Guard Panels
 36" x 48" Platform with Non-skid Surface
 15 1/2" long Automatic Folding Access Ramp
 750 lb. Capacity
 Ivory White Powder Coat Finish
 ETL Listed when appropriately equipped
 3/4 HP Motor, 115 V, 60 Hz, 15 Amp
 Acme Screw Drive
 V-Belt Drive System with Monitoring Device
 ASME/ANSI A18.1 (formerly A17.1: Part XX, Section 2100 for private residences) when appropriately equipped with Options.
 Electrical by others. Must meet NEC or local requirements.
 Supply voltage: 115 VAC, 60 Hz, 20 Amp

OPTIONAL EQUIPMENT

42" high Top Landing Gate (not shown)
 Access ESI (doors & gates by others), not shown
 Flush Mount Electric Stike (at top landing only) (door/gate by others), not shown
 Keyed Dead Latch (for use w/Flush Mount Electric Strike)
 Fascia Panel, 36" wide
 Manual Lowering Device
 Hand Rail
 Wireless Remote

4001 East 138th Street
 Grandview, MO 64030-2837
 Phone: 816-763-3100
 Fax: 816-763-4467
 Toll Free: 800-925-3100
 www.tkaccess.com

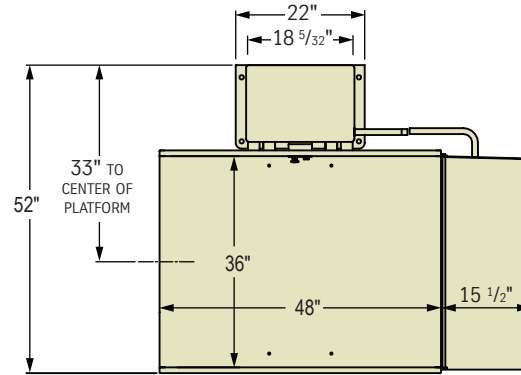

PLAN VIEW

Model PL-RA750			
Model	Max. Lifting Ht.	Min. Lifting Ht.	Tower Height
24	25"	0"	65.5"
36	37"	24" 12" *	77.5"
50	51"	36" 26" *	91.5"
72	73"	60" 48" *	113.5"

*With extender kit.

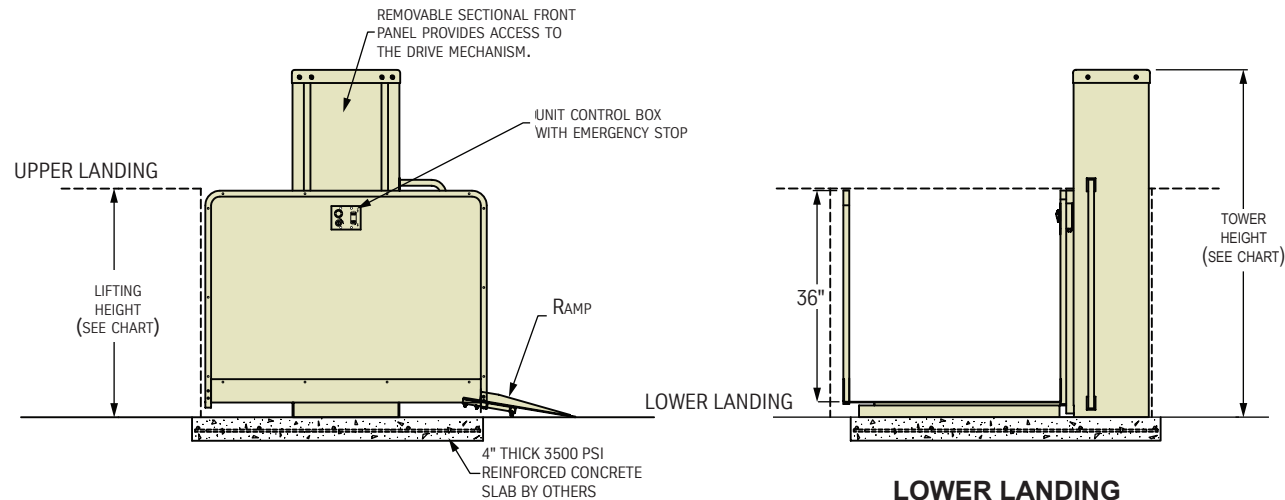

FRONT ELEVATION
Right Hand Unit Shown

LOWER LANDING
SIDE ELEVATION

ThyssenKrupp Access
 Accessibility Division



ThyssenKrupp