

MODEL #	BPH	TPH	MTPH
GLC-05-4X3-08	225	6.3	5.7
GLC-05-4X3-07	255	7.1	6.5
GLC-05-4X3-06	300	8.4	7.6
GLC-05-4X3-05	360	10.1	9.1
GLC-05-4X3-04	450	12.6	11.4
GLC-09-6X4-06	750	21	19.1
GLC-09-6X4-05	900	25.2	22.9
GLC-16-9X5-12	1,550	43.4	39.4
GLC-16-9X5-09	2,100	58.8	53.3
GLC-16-9X5-06	3,100	86.8	78.7
GLC-24-9X6-08	3,400	95.2	86.4
GLC-24-9X6-07	3,900	109.2	100
GLC-24-11X7-09	5,000	140	127
GLC-24-11X7-08	5,700	159.6	144.8
GLC-30-9X6-10	3,000	84	76.2
GLC-30-9X6-09	3,400	95.2	86.4
GLC-30-9X6-08	3,800	106.4	96.5
GLC-30-9X6-07	4,400	123.2	111.7
GLC-30-11X7-10	5,200	145.6	132
GLC-30-11X7-09	5,700	159.6	144.8
GLC-30-11X7-08	6,500	182	165
GLC-36-12X7-11	5,900	165.2	149.8
GLC-36-12X7-10	6,400	179.2	162.5
GLC-36-12X7-09	7,000	196	177.7
GLC-36-12X7-08	8,000	224	203
GLC-36-12X8-9.5	9,000	252	228.6
GLC-36-12X8-8.5	10,000	280	254
GLC-42-16X8-12	10,000	280	254
GLC-42-16X8-10	12,000	336	304.7
GLC-42-16X8-09	13,500	378	342.8
GLC-42-18X8-10	13,900	389	353
GLC-42-18X8-8.5	16,300	459	416.5
GLC-42-20X8-8.5	18,400	515	467.3
GLC-42-20X8-07	20,000	560	507.9
GLC-42D-16X8-10	24,000	672	609.5
GLC-42D-16X8-09	27,000	756	685.7
GLC-42D-18X8-8.5	32,000	896	812
GLC-42D-20X8-8.5	36,000	1,008	914
GLC-42D-20X8-07	40,000	1,120	1,015

\* CAPACITIES ARE EXAMPLES BASED ON CENTRIFUGAL DISCHARGE SPEEDS FOR WHOLE GRAINS.  
 \* CAPACITIES ARE BASED ON 56# SHELLED CORN OR GRAIN SORGHUM @ 15.5% MOISTURE.  
 \* SLOW CENTRIFUGAL AND GRAVITY DISCHARGE SPEED CAPACITIES ARE AVAILABLE UPON REQUEST.

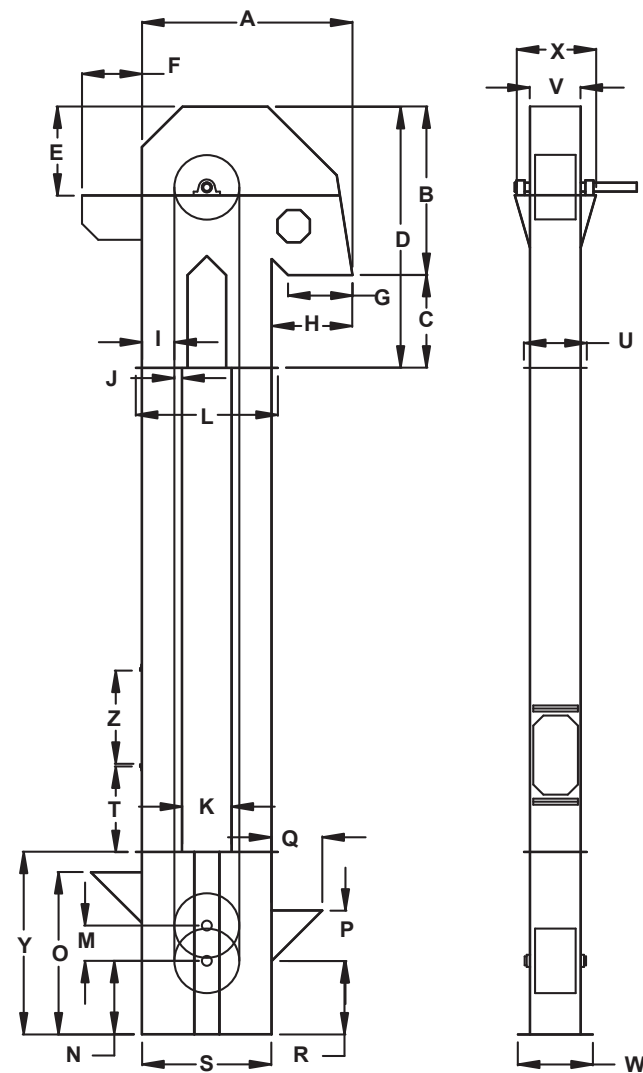

DIMENSION	2 ROWS OF BUCKETS											
	05 - 4X3	09 - 6X4	16 - 9X5	24 - 9X6	24 - 11X7	30 - 9X6 / 11X7	36 - 12X7 / 12X8	42 - 16X8	42 - 18X8 / 20X8	42D - 16X8	42D - 18X8	42D - 20X8
A	27	42	52	60	69 1/2	88 1/4	95 3/4	109 1/4	109 1/4	109 1/4	109 1/4	109 1/4
B	28	38	42	51 3/4	63	77 3/4	77 3/4	94 1/4	94 1/4	94 1/4	94 1/4	94 1/4
C	0	0	23	19	14 3/4	3 3/16	6 1/2	0	0	0	0	0
D	28	38	65	70 3/4	77 3/4	80 15/16	83 3/4	94 1/4	94 1/4	94 1/4	94 1/4	94 1/4
E	13	16	19 3/4	N/A	N/A	N/A	N/A	83	83	83	83	83
F	12	14 3/4	14 1/4	N/A	N/A	N/A	N/A	N/A	N/A	N/A	N/A	N/A
G	8 1/2	9 1/2	13	13 1/2	13 1/2	19	19	18 5/8	18 5/8	18 5/8	18 5/8	18 5/8
H	12 5/8	17 1/2	17	16 3/4	23	34 3/16	34 3/16	39 7/16	39 7/16	39 7/16	39 7/16	39 7/16
I	14	21 5/8	9	9	11 1/4	11 1/4	12	14	14	14	14	14
J	1 1/8	1 1/2	7/8	7/8	7/8	7/8	7/8	1 3/4	1 3/4	1 3/4	1 3/4	1 3/4
K	N/A	N/A	12 1/4	20 1/4	18 1/4	26 1/4	32 1/4	38 1/4	38 1/4	38 1/4	38 1/4	38 1/4
L	16 1/2	24 1/2	36	44	46 1/2	54 1/8	62	70	70	70	70	70
M	4	7	8 3/4	8 3/4	8 3/4	12	12	12	12	12	12	12
N	12	11 1/2	18 1/4	18 1/4	21 1/2	24 3/4	27	23	23	23	23	33
O	20 7/8	25 3/8	39	39	41 1/2	52 3/4	55	52	52	52	52	52
P	6	12	12	12	12	16	17	17	17	17	17	17
Q	6	12	12	12	12	16	17	17	17	17	17	17
R	14 7/8	17 1/4	18 1/4	18 1/4	20 3/4	24 3/4	27	23	23	23	23	23
S	15	22	32	40	43 3/4	50 13/16	58	70	70	70	70	70
T	N/A	12	12	12	12	12	12	12	12	12	12	12
U	8 1/2	11 3/4	15 1/2	15 1/2	18	18	21	23	29 3/4	44	48	52
V	6	9	12 1/2	12 1/2	15	15	17	20	26	39 5/8	43 5/8	47 5/8
W	9	12	16 1/2	18 1/2	20	20	23 3/4	27 1/2	35 1/2	47 3/16	51 3/16	55 3/16
X	12 1/2	16	20	20	24 1/4	24 1/4	30 1/4	33 1/4	41 1/4	54 11/16	58 11/16	62 11/16
Y	60 or 120	33 1/2	45 1/4	45 1/4	45 1/4	56 5/8	56 5/8	65 1/2	65 1/2	65 1/2	65 1/2	65 1/2
Z	36	36	36	36	36	36	36	36	36	36	36	36

ALL DIMENSIONS ARE IN INCHES; INTENDED FOR LAYOUT PURPOSES ONLY AND ARE SUBJECT TO CHANGE WITHOUT NOTICE.

1247 FLORENCE RD. FLORENCE, ON. CANADA, N0P 1R0 Ph:1.888.239.9713 Fx: 1.519.695.2529

<http://www.lambtonconveyor.com>

[sales@lambtonconveyor.com](mailto:sales@lambtonconveyor.com)



LBE081001

Lambton is a trademark of Lambton Conveyor Limited.



# BUCKET ELEVATORS

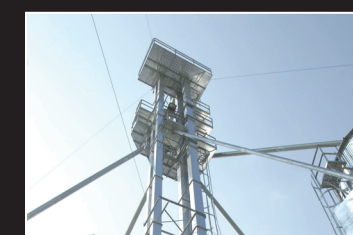

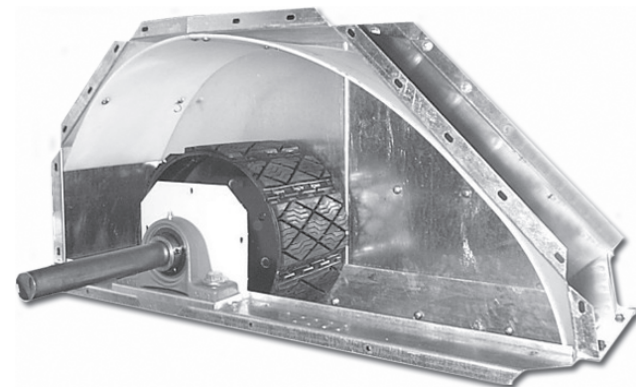

**Elevator Head Assembly Standard Features:**

- CNC designed and manufactured
- 10 gauge galvanized construction
- 1/4" thick UHMW CAD designed curved head line with easy replacement
- Heavy duty pillow block roller bearings with vertical and horizontal adjustments
- Turned, ground and polished shaft
- 14 gauge head cover splits for easy removal and inspection
- Inspection door on both sides of head
- Dust protection at shaft opening
- Ladder section on head unit
- No welding or torch cutting on head assembly
- Replaceable head pulley lagging

**Trunk Section Standard:**

- CNC designed and manufactured
- 10 - 14 gauge bolted construction
- Removable side panel for inspection
- Flanges weld to trunking using only silicon-bronze MIG wire to prevent corrosion and extend the useful life of the bucket elevator
- Double legged trunking assemblies are used for quicker assembly of the bucket elevator.
- Standard PVC Belting with Rubber Belting as an option
- Poly buckets are also standard; other options available upon request

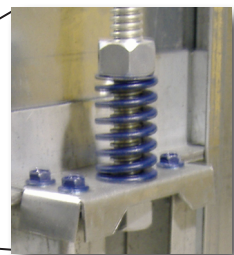
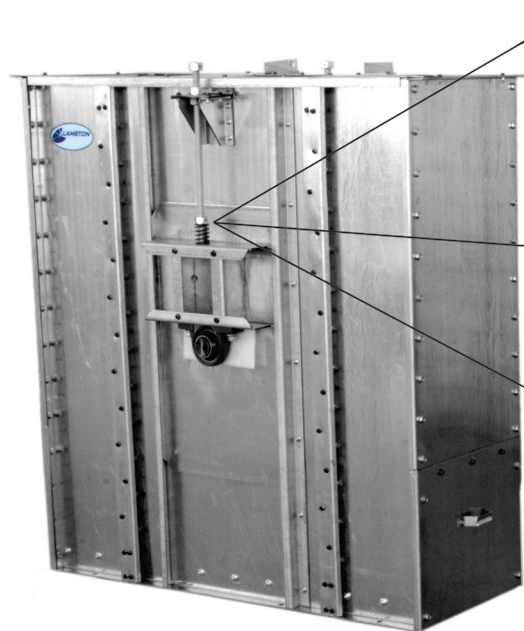

**Elevator Boot Assembly Standard Features:**

- CNC designed and manufactured
- 10 and 8 gauge galvanized construction
- Heavy duty pillow block ball bearings
- 1-1/2" Die springs on each belt take-up assembly, insure proper tensioning of belt for better traction and longer life.
- Turned, ground and polished shaft
- 13" Belt Adjustment for easy installation
- Dust protection at shaft opening
- Rod slatted and crowned pulley
- No welding or torch cutting on assembly



Lambton ladders and platforms allow easy access up your equipment with optional safety cage, rest platforms, work platforms and head platforms. Each platform includes a full hand rail set as well as a large swing door in the floor for fall prevention.



Lambton Flow Accessories range from a variety of valves to flow reducers and custom transitions. Lambton accessories are in stock and ready to ship.

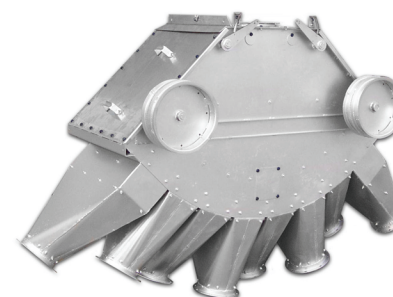

**Pendulum - Flat Back - Full Round Distributors:**

- Galvanized weather tight enclosure
- Large inspection door
- Heavy duty long lasting construction
- Positive position locking
- Sure flow with 50 degree angle
- Round flange inlet & outlets

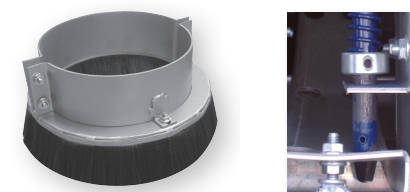

**Electric Distributor:**

The SG-383 combines state of the art touch screen technology and a durable DC drive control to offer outstanding performance. The entire process is being continuously monitored by the onboard CPU to ensure accurate positioning at all times.



**BUCKET ELEVATOR**

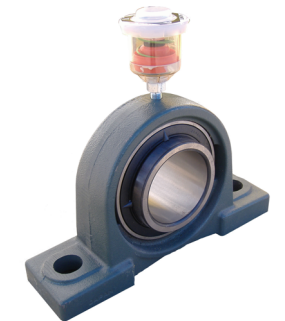

Option: Auto grease bearings ensure your bearings always have the proper amount of lubricant while you remain safely on the ground.



Option: Motion sensor monitors the boot shaft rpm to ensure that the bucket elevator is running to its full capacity. It may be programmed to shut down equipment if it senses a reduction in the boot shaft speed.

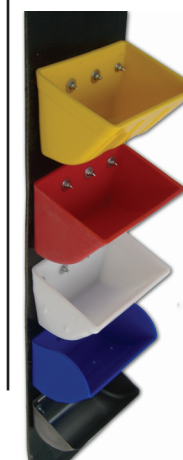

Standard buckets are constructed of a durable non-sparking polyethylene. Optional steel, nylon or urethane buckets also available.



1247 FLORENCE RD. FLORENCE, ON. CANADA, N0P 1R0 Ph:1.888.239.9713 Fx: 1.519.695.2529

<http://www.lambtonconveyor.com>

[sales@lambtonconveyor.com](mailto:sales@lambtonconveyor.com)



ONE SOURCE. ONE SOLUTION