

Hardware & Miscellaneous Items:

A	2	3 1/2" chest handles
B	7	3" T-hinges and screws
C	4	1/4" T nuts
D	4	1/4" x 2 1/2" Carage bolts
E	2	1/4" x 2" Barrel Bolts
F	2	1" x 5' Straps
G	8	1/4" 3 1/2" Carage Bolts w/ washers and wing nuts

Raw Materials Lumber List

3	2 x 4 x 8' or 6 - 2 x 2 x 8'
3	1 x 8 x 8'
3	1 x 3 x 8'
4	4 x 8 x 1/4" Plywood

I prefer sandyply it has more laminates and is made for cupboard making

Lumber and Plywood cut list**Section #1**

1	2	3/4" x 7" x 82 1/2"
2	1	1/4" x 16 3/8 x 84"
3	4	1/4" x 1 5/8" x 84"
4	2	1 1/2" x 1 1/2" x 15 7/8"
5	1	1 1/2" x 1 1/2" x 20"

Upper leg brace - figure 6

6	1	3/4" x 4 3/4" x 15 7/8"
7	2	3/4" x 2 1/2" x 39"
8	2	3/4" x 2 1/2" x 15 3/4"

Lower leg brace w/ horizontal brace - figure 8

9	1	3/4" x 2 1/2" x 15 7/8"
10	2	3/4" x 2 1/2" x 20 1/2"
11	2	3/4" x 2 1/2" x 15 3/4"
12	1	3/4" x 2 1/2" x 51"
13	2	3/4" x 2 1/2" x 2 1/2"

Starting gate - figure 7

14	1	3/4" x 4" x 15 7/8"
15	1	3/4" x 6 3/4" x 15 3/8"

Section #2

5	2	1 1/2" x 1 1/2" x 20"
16	1	1/4" x 15 3/4" x 82 1/2"
17	4	1/4" x 1 5/8" x 82 1/2"

Section #3

5	2	1 1/2" x 1 1/2" x 20"
18	1	1/4" x 15 3/4" x 79 1/4"
19	4	1/4" x 1 5/8" x 79 1/4"

Section #4

5	2	1 1/2" x 1 1/2" x 20"
20	1	1/4" x 15 3/4" x 76"
21	4	1/4" x 1 5/8" x 76"

Section #5

5	2	1 1/2" x 1 1/2" x 20"
22	2	1 1/2" x 1 1/2" x 69 3/4"
23	1	1/4" x 15 3/4" x 72 3/4"
24	4	1/4" x 1 5/8" x 72 3/4"
25	4	1/4" x 1 5/8" x 16"

Section #6 (OPTIONAL)

5	2	1 1/2" x 1 1/2" x 20"
29	1	1/4" x 15 3/4" x 23"
30	8	1/4" x 1 5/8" x 23"

Storage Cover

26	2	1 1/2" x 1 1/2" x 17"
27	1	1/4" x 15 3/4" x 84"

Track Support Blocks

28	4	1 1/2" x 1 1/2" x 15 3/4"
----	---	---------------------------

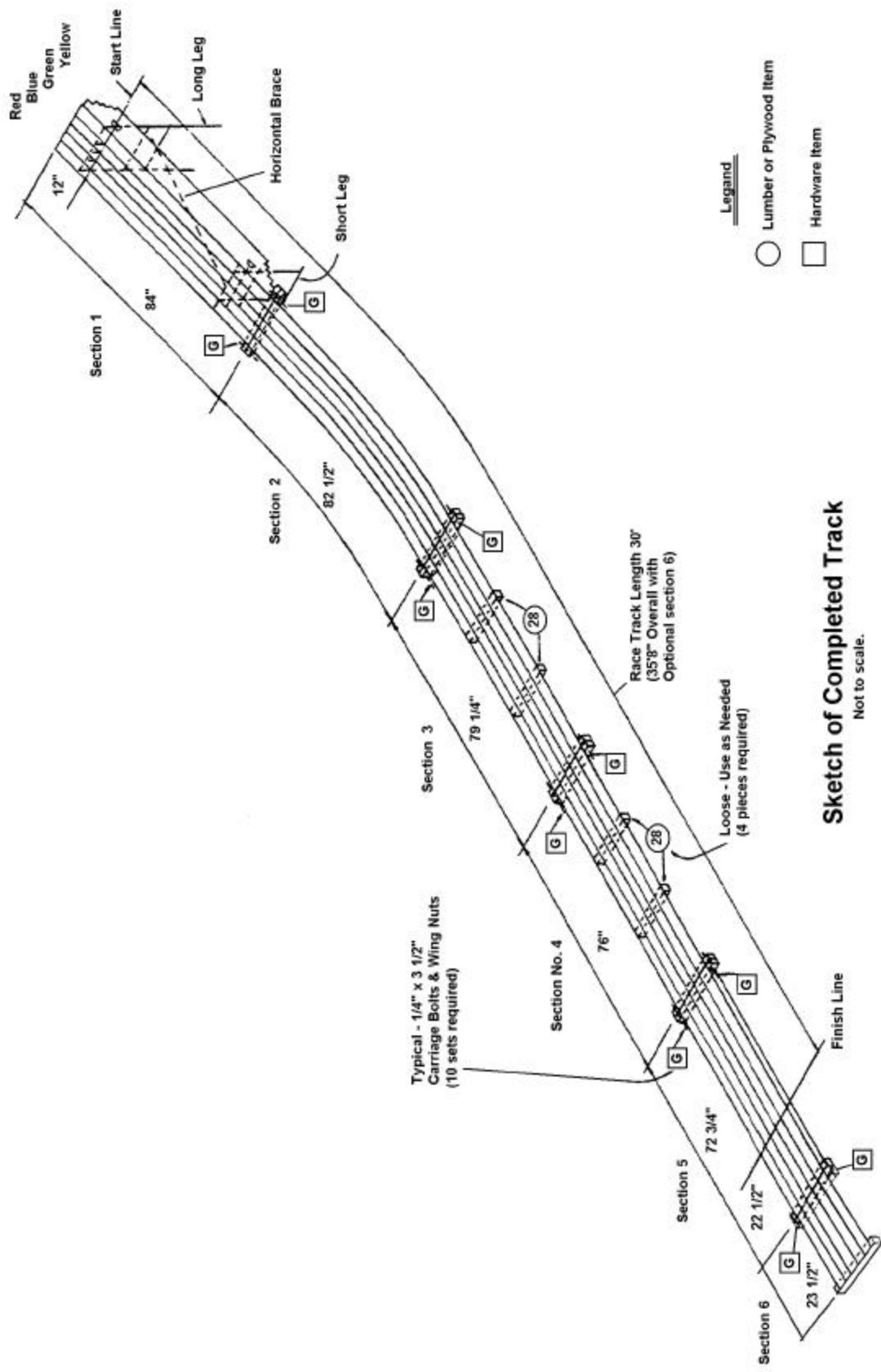

- Legend**
- Lumber or Plywood Item
 - Hardware Item

Sketch of Completed Track
 Not to scale.

Typical - 1/4" x 3 1/2"
 Carriage Bolts & Wing Nuts
 (10 sets required)

Loose - Use as Needed
 (4 pieces required)

Race Track Length 30'
 (35'8" Overall with
 Optional section 6)

Section 1 Top View

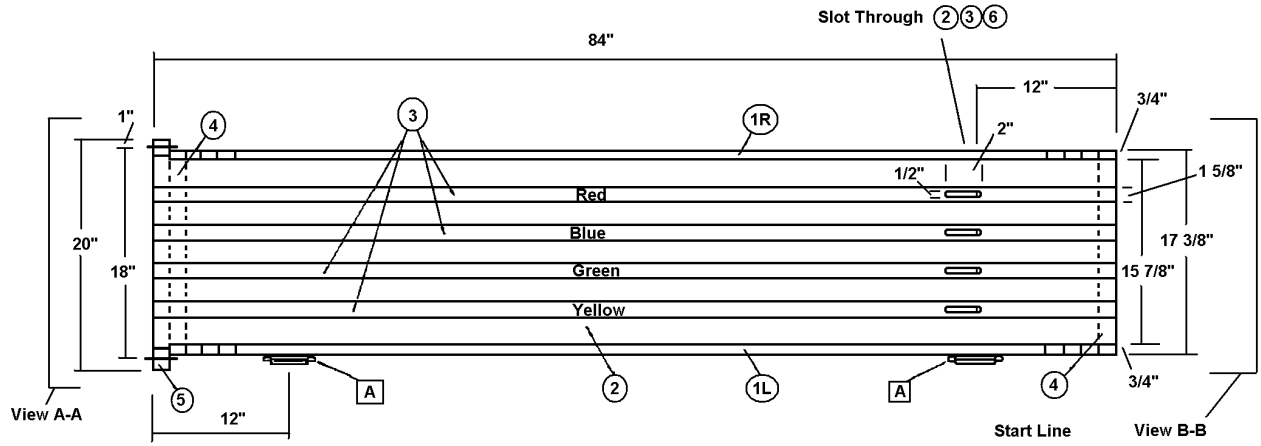

Section 1 Side View

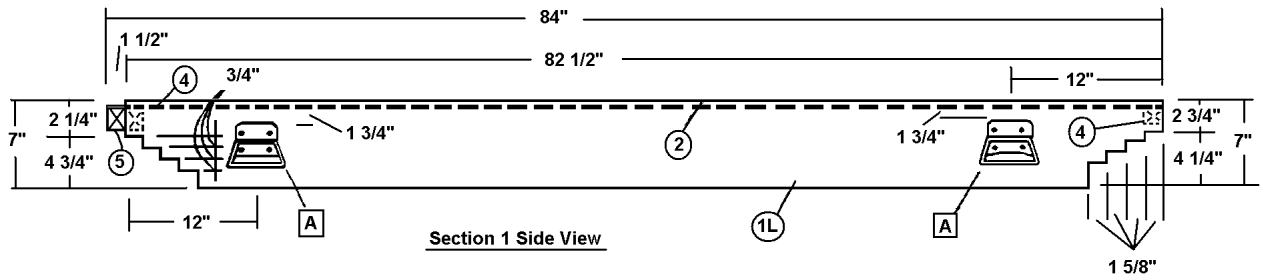

Section 1 Bottom View Figure 3

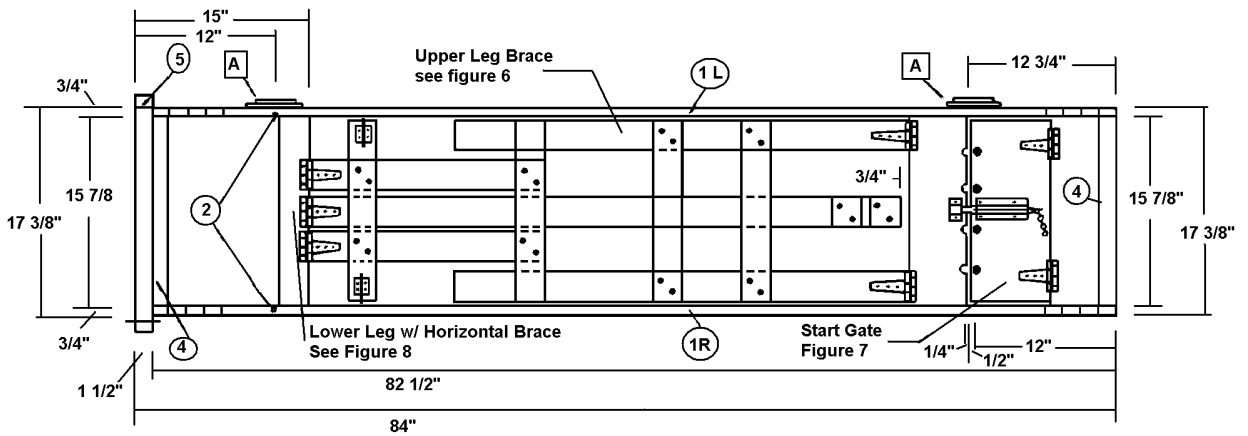

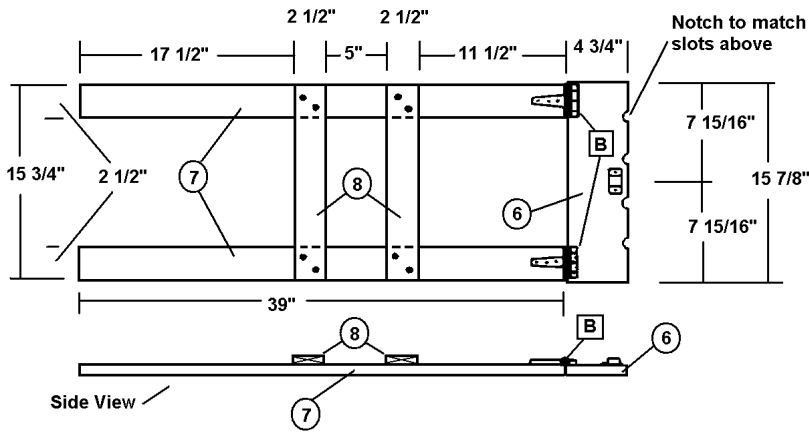
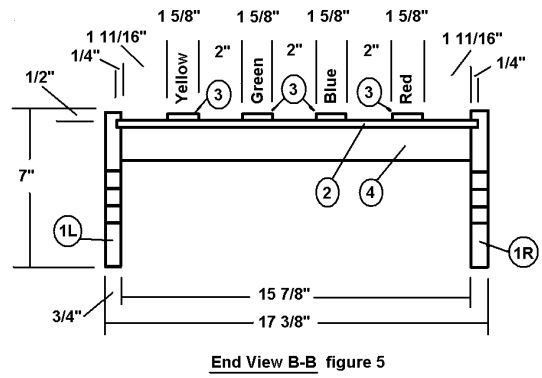
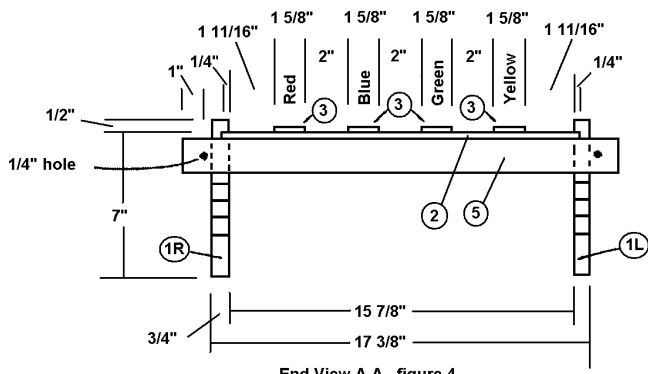

Upper Leg Brace figure 6

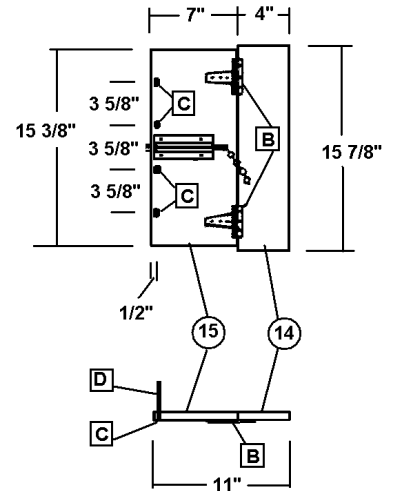

Starting Gate figure 7

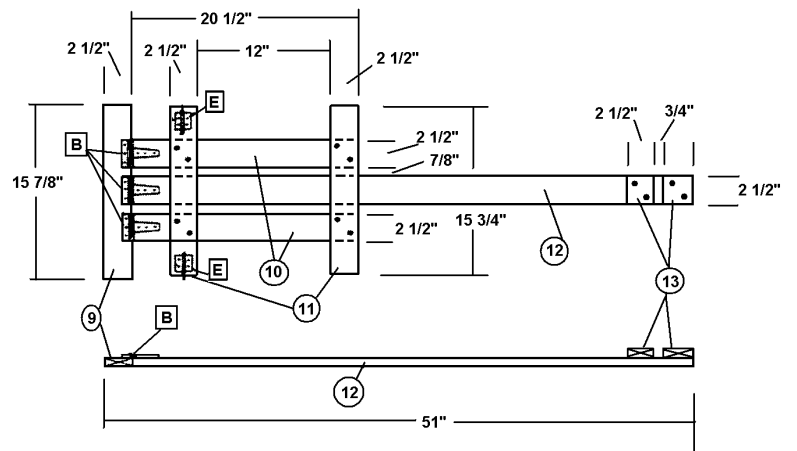
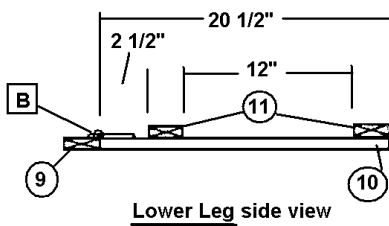

Lower Leg Brace with Horizontal Brace figure 8

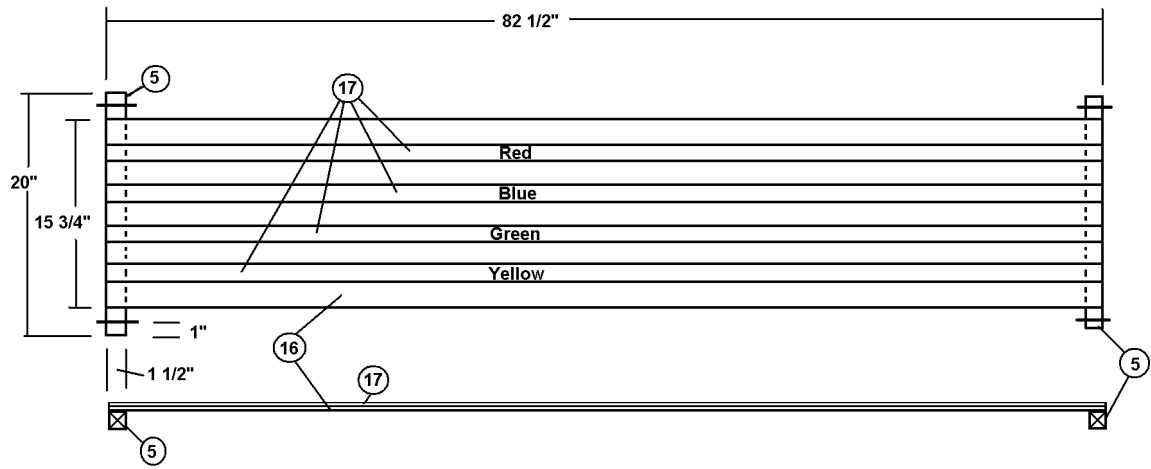

Section 2

Section 3

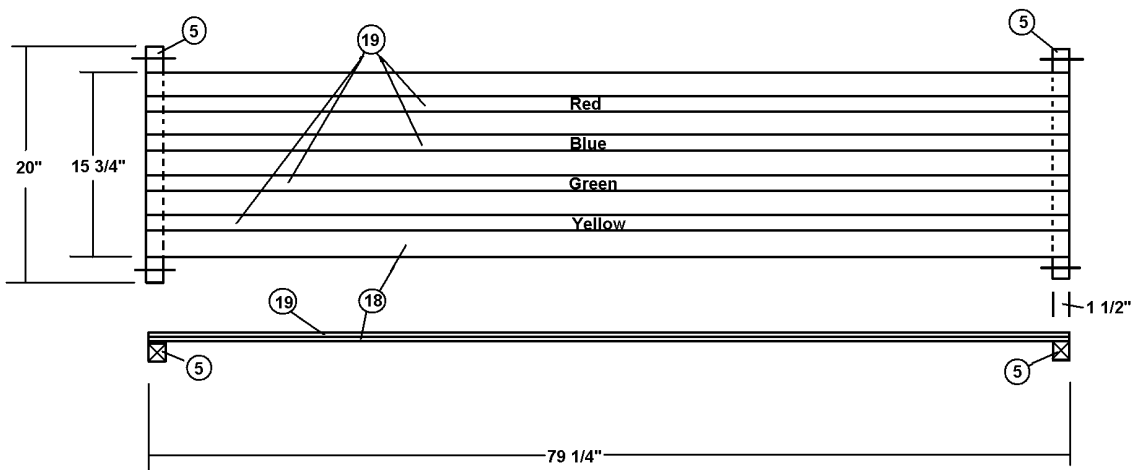

Section 4

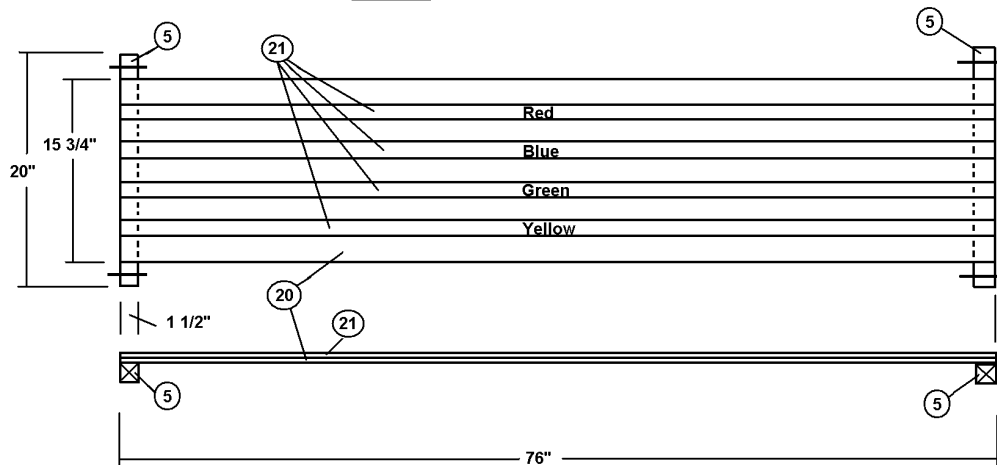

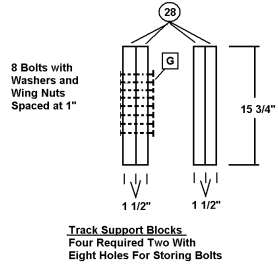
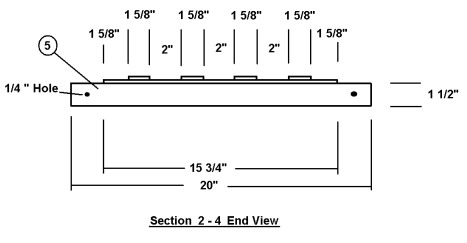
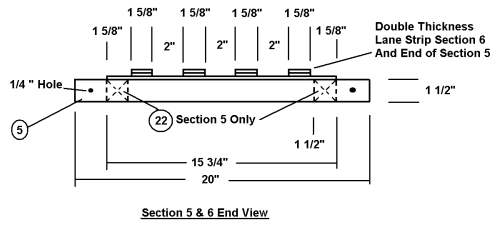
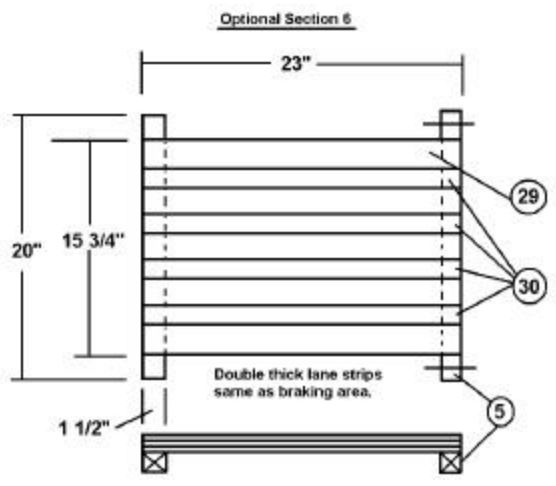
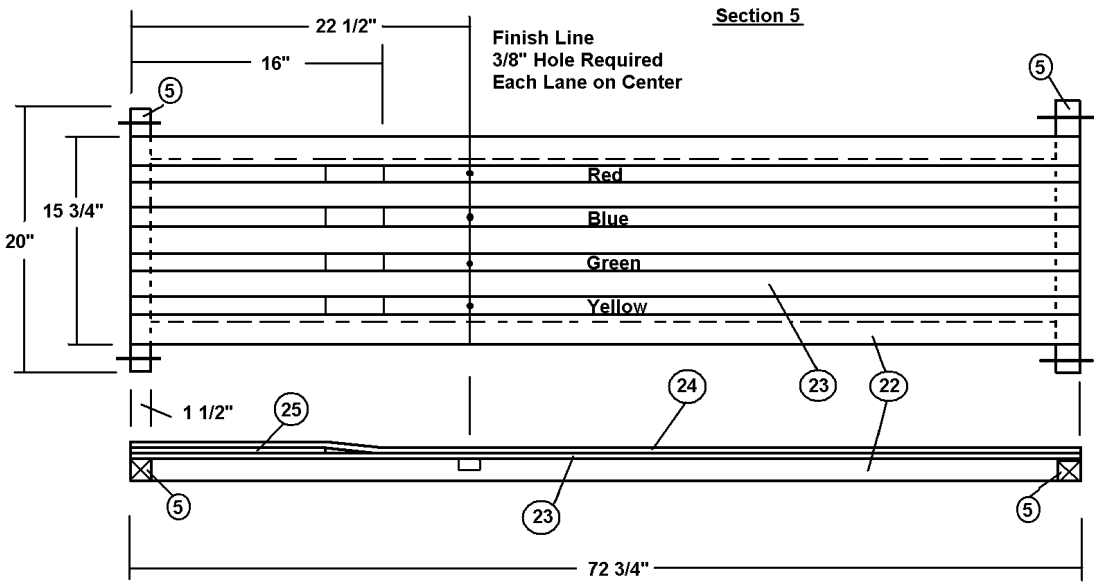

Storage Cover

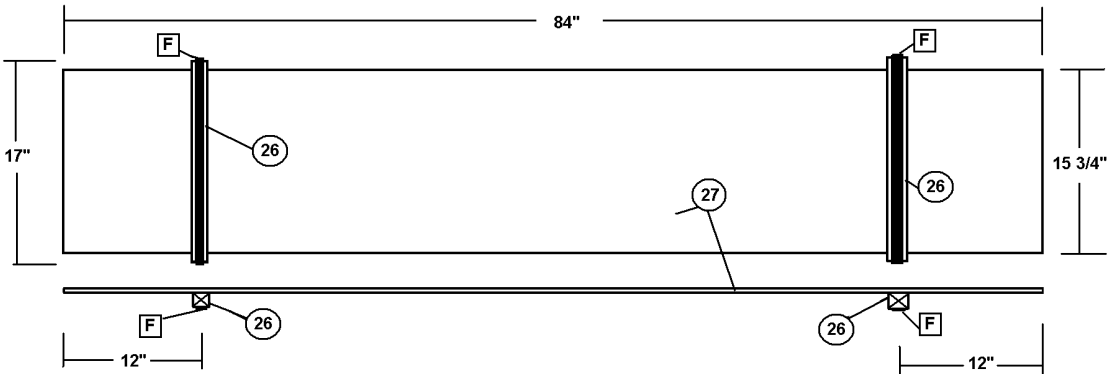

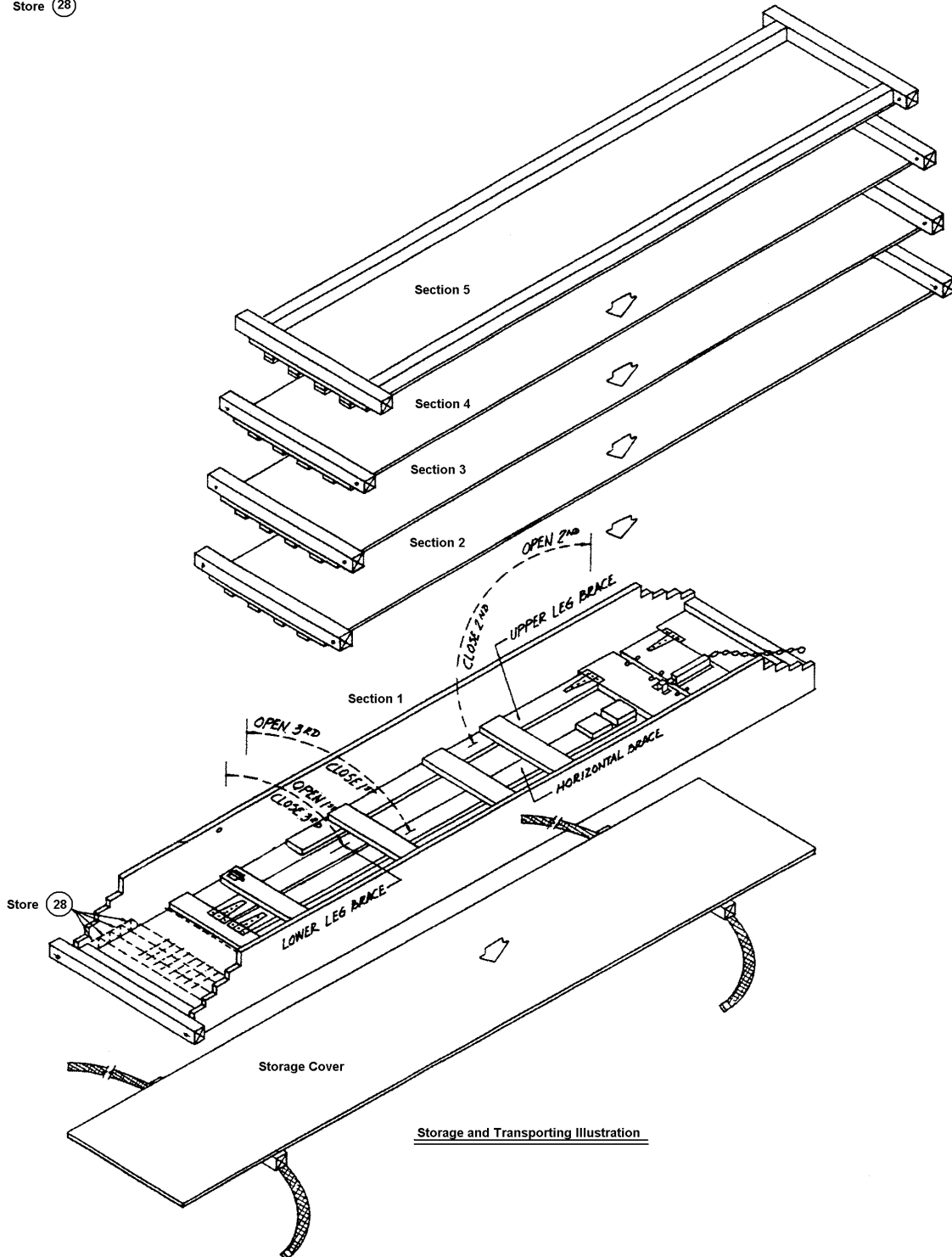
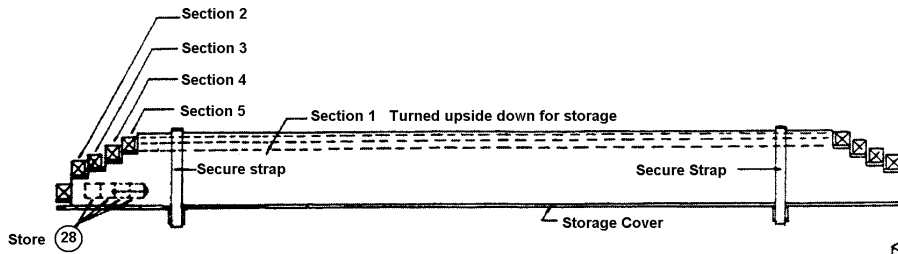

Storage and Transporting Illustration

INSTRUCTIONS:

1. Cut raw materials to specified sizes; be careful to make cuts square and smooth.
2. Use a large square to center and square 2"x2"x20" pieces at ends of sections 2-6 then glue and nail together
3. Locate 1 5/8"x1/4" lane strips, snap chalk lines the entire length of the track on all four lanes. Glue and nail with 1/2" wire brads to plywood track sections.
4. Cut the 16" lengths of the lane strips for the slow down end, install on section 5 before attaching lane strips for a smoother transition.
5. It is suggested that the track strips be custom cut to length to avoid gaps rather than pre-cut to length. Also taper the leading end of the strips slightly to prevent cars from catching on any edges at the joints.
6. Cut the 1x8s to 82 1/2" long, and rip to 7" wide, tack two sides together. Mark the sides so pieces are assembled in the same direction as cut.
7. Next cut the dado along the top edges of the side boards; use the inside surfaces so pieces will match when assembled. The dado is best done with a router but can be done with a table saw or can be accomplished with a skill saw by clamping a guide on the saw table. I suggest using a scrap piece of wood to test cut the groove before making the cut on the finished product. Make the first cut 1/2" down and 1/4" deep, then move the saw guide 1/8" for the second cut until the dado is wide enough for a snug fit on the plywood.
8. Take section 1 and glue sides in place. At the same time install the 2"x2"x15 3/4" pieces on each end to help hold it together. Clamp together and nail to help hold together while glue cures. Most good wood glues cure in 20-30 minutes.
9. Cut starting gate pin slots as specified on drawing
5. Drill holes at each end of the slot with 1/2" or 5/8" bit, then cut sides straight with thin saw blade. File to make smooth.
10. Assemble leg sections on underside of track instead of separately. This insures all parts lining up with adequate clearance between components; use a square for alignment. Glue and screw parts together; install hinges and barrel bolts. With help set up section on the legs and align leg at 90 degrees to the floor and mark the locations; drill holes for barrel bolts in the section side.
11. Assemble starting gate mechanism as shown in drawings 2 & 5, holes for starting pegs should be drilled with starting block in place to insure alignment of pegs in slots. Be sure all pegs are straight and in line. Insert T nuts from below, check bolts for length before cutting heads off. They can be removed for storage.
12. The track will require testing and some adjustments may be necessary. It is suggested that 4 test cars should be used to check the track before each use, rotating the cars on the lanes. If the track is adjusted well, these test cars should finish in the same order regardless of which lane they are assigned.
13. Seal all surfaces with white shellac, varnish or polyurethane to prevent moisture from causing the track to warp. Sand lightly with sandpaper, paint colour on lane surfaces as desired, then apply a second coat over everything.
14. The protective storage cover with straps hold the track together while stored and in transport.

While Grand Prix is fun and an interesting addition to the club program, it's primary goal is to reach parents for Christ. As parents visit to observe their child's race entry, they often come with a car they have helped design and build themselves. Many decisions for Christ have resulted from this activity.