

TRUCK FEATURES

STANDARD EQUIPMENT

Iron Phosphate Battery Technology
Battery 80V • 21.6 kWh • 270Ah
Charger 80V • 200A
80V AC Drive Motor
Regenerative Braking
LED Lights (Front • Rear • Strobe)
LCD Display
4-Way Hydraulic Valve
Rear Grab-Handle with Horn
Rearview Mirrors

STANDARD SAFETY FEATURES

Cornering Speed Reduction
Ramp Hold Assist
Operator Presence Sensor (OPS)

OPTIONAL EQUIPMENT

Grammer® Suspension Seat
Synchronized Steering
Blue Light
Rear Working Light
Tablet Mount
Full or Partial Cab Enclosure
Universal 110V Wall Charger
Charger 80V • 100A
Panoramic Mirror



BYD Motors LLC

1800 S Figueroa St., Los Angeles, CA 90015

BYD Forklift production site is certified:

ISO 9001 ISO 14001 OHSAS 18001



1-800-293-2886



sales@byd-forklifts.com



www.byd-forklifts.com



BYD trucks conform to the
United States Safety Requirements
All BYD forklifts comply with ANSI B56.1

FORKLIFTS SIMPLIFIED

ECB16S/18S



SAFE



RELIABLE



PROVEN

- 80V AC Technology
- Rapid, Restriction-Free Charging
- No Battery Maintenance Required
- 10-Year or 20,000-Hour Battery Warranty



With rapid, restriction-free charging, BYD forklifts operate across multiple shifts without the need to change or replace batteries. Built using iron-phosphate technology, each forklift includes a state-of-the-art Battery Management System and the longest battery warranty in the industry. With BYD, peace of mind is assured.

ECB16S/18S SPECIFICATIONS

			ECB16S	ECB18S	
	Load capacity: rated load to 118" @ 24" LC	lb	3500	4000	
	Operating voltage	v	80 volts	80 volts	
Dimensions	Length to face of forks	l2	in	83.6	83.6
	Minimum turning radius	Wa	in	73.2	73.2
	Load distance, center wheel to face of forks	x	in	14.4	14.4
	Basic right-angle stack (add load and clearance)		in	87.8	87.8
	Overall width	b1	in	41.7	41.7
	Seat height	h7	in	38.8	38.8
	Overhead guard height	h6	in	80.7	80.7
	Carriage width	b3	in	40.1	40.1
	Carriage ITA Type			II	II
	Tilt range (forward/backward)		deg	5/7	5/7
	Ground clearance with load, below mast	m1	in	3.74	3.74
Performance	Travel speed (loaded/unloaded)	MPH	10 / 10	10 / 10	
	Lift speed (loaded/unloaded)	FPM	100 / 108	100 / 108	
	Lowering speed (loaded/unloaded)	FPM	105 / 98	105 / 98	
	Max gradeability (loaded/unloaded)	%	20 / 20	20 / 20	
Power System	Drive motor rating (S2=60 min)	KW	8.5	8.5	
	Lift motor rating (S3=15% ED)	KW	16	16	
	Battery capacity	KWh	21.6	21.6	
	Charging time		1.4h	1.4h	
	Battery weight	lb	1410.0	1410.0	
	Type of drive control		AC	AC	
Weight	Service weight including battery	lb	6836	7276	
	Axle load, fully loaded (front/rear)	lb	9003 / 1360	9911 / 1334	
	Axle load, unloaded (front/rear)	lb	3231 / 3602	3419 / 3855	
Tires	Wheel size, front wheel or driving wheel	Spec	18*7-8	18*7-8	
	Wheel size, rear wheel or supporting wheel	Spec	15*4.5-8	15*4.5-8	
	Track width front	b10	in	35.0	35.0
	Track width rear	b11	in	34.25	34.25

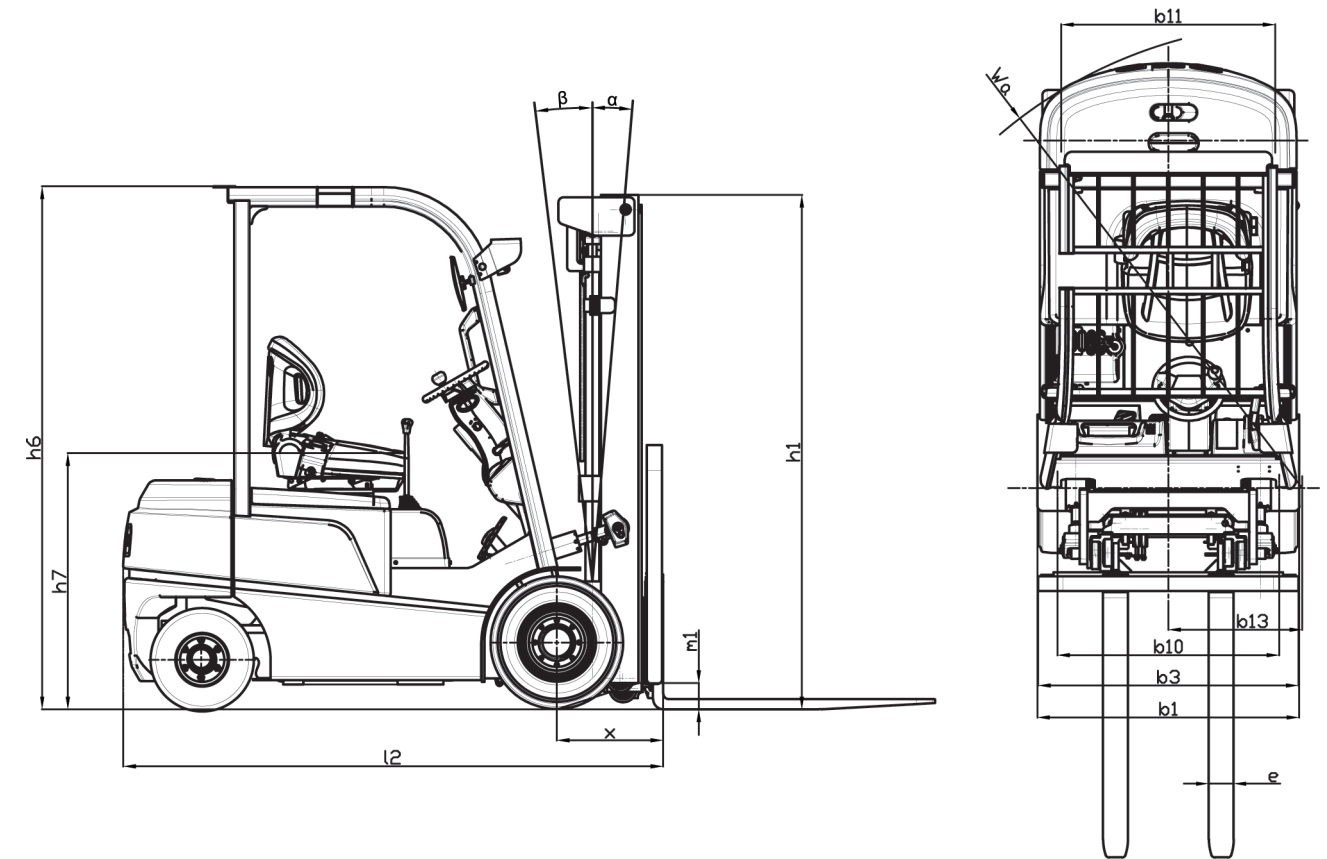

MAST SPECIFICATIONS

Mast Specifications (in)	Fork Height	Free Lift	Collapsed Height	Extended Height	Fwd Tilt	Back Tilt	Capacity 24" LC	
							ECB16S	ECB18S
2-Stage Standard Mast	118	5	80	157	5°	7°	3527	3968
	130	5	85	169	5°	7°	3527	3968
	138	5	89	177	5°	7°	3527	3968
	157	5	101	196	5°	7°	3508	3843
	177	5	111	216	5°	5°	3283	3609
2-Stage FFL Mast	197	5	123	236	5°	5°	2937	3236
	118	41	80	157	5°	7°	3527	3968
	130	47	85	169	5°	7°	3527	3968
3-stage FFL Mast	138	51	89	177	5°	7°	3527	3968
	157	62	101	196	5°	7°	3508	3843
	177	42	83	216	5°	5°	3283	3609
	189	46	87	228	5°	5°	3201	3521
	197	48	89	236	5°	5°	2937	3236
	217	56	95	255	5°	3°	2789	3080
3-stage FFL Mast	236	66	105	275	5°	3°	1892	1750
	256	74	112	295	5°	3°	1193	1091

*BYD reserves the right to alter and modify the design, features and technical parameters of its products at any given time and without prior notice, as products are subject to continuous development.