

TRUCK FEATURES

STANDARD EQUIPMENT

Iron Phosphate Battery Technology
Battery 80V • 43.2 kWh • 540Ah
Charger 80V • 200A
Dual 80V AC Drive Motors
Regenerative Braking
LED Lights (Front • Rear • Strobe)
LCD Display
4-Way Hydraulic Valve
Rear Grab-Handle with Horn
Rearview Mirrors

STANDARD SAFETY FEATURES

Cornering Speed Reduction
Ramp Hold Assist
Operator Presence Sensor (OPS)
Orange Seatbelt with Interlock

OPTIONAL EQUIPMENT

Battery 80V • 64.8 kWh • 810Ah
Universal 110V Wall Charger
Charger 80V • 100A
Charger 80V • 300A
Grammer® Suspension Seat
Fingertip Controls
Dual Joystick Controls
Synchronized Steering
Blue Light
Rear Working Light
Full or Partial Cab Enclosure



BYD Motors LLC

1800 S Figueroa St., Los Angeles, CA 90015

BYD Forklift production site is certified:

ISO 9001 ISO 14001 OHSAS 18001



1-800-293-2886



sales@byd-forklifts.com



www.byd-forklifts.com



BYD trucks conform to the
United States Safety Requirements
All BYD forklifts comply with ANSI B56.1

FORKLIFTS SIMPLIFIED

ECB 40, 45, 50



SAFE



RELIABLE



PROVEN

- 80V AC Technology
- Rapid, Restriction-Free Charging

- No Battery Maintenance Required
- 10-Year or 20,000-Hour Battery Warranty



With rapid, restriction-free charging, BYD forklifts operate across multiple shifts without the need to change or replace batteries. Built using iron-phosphate technology, each forklift includes a state-of-the-art Battery Management System and the longest battery warranty in the industry. With BYD, peace of mind is assured.

ECB 40, 45, 50 SPECIFICATIONS

ECB 40, 45, 50				
	Load capacity: rated load to 118" @ 24" LC		lb	ECB40 8800 ECB45 9900 ECB50 10700
	Operating voltage		v	80 volts
Dimensions	Length to face of forks	l2	in	114.70
	Minimum turning radius	Wa	in	102.5
	Load distance, center wheel to face of forks	x	in	21.7
	Basic right-angle stack (add load and clearance)		in	124.17
	Overall width	b1	in	59.8
	Seat height	h7	in	48.0
	Overhead guard height	h6	in	93.0
	Carriage width	b3	in	57.1
	Carriage ITA Type			III / IV
	Tilt range (forward/backward)		deg	5/8
	Ground clearance with load, below mast	m1	in	5.91
Performance	Travel speed (loaded/unloaded)		MPH	11 / 11
	Lift speed (loaded/unloaded)		FPM	70 / 90
	Lowering speed (loaded/unloaded)		FPM	100 / 80
	Max gradeability (loaded/unloaded)		%	20 / 20
Power System	Drive motor rating (S2=60 min)		KW	15x2
	Lift motor rating (S3=15% ED)		KW	25.4
	Battery capacity		KWh	43.4 / 64.8
	Charging time			2.7h
	Battery weight		lb	19250.0
	Type of drive control			AC
Weight	Service weight including battery		lb	16207
	Axle load, fully loaded (front/rear)		lb	24166 / 3064
	Axle load, unloaded (front/rear)		lb	7320 / 8886
Tires	Wheel size, front wheel or driving wheel		Spec	28*12.5-15
	Wheel size, rear wheel or supporting wheel		Spec	21*8-9
	Track width front	b10	in	47.9
	Track width rear	b11	in	40.6

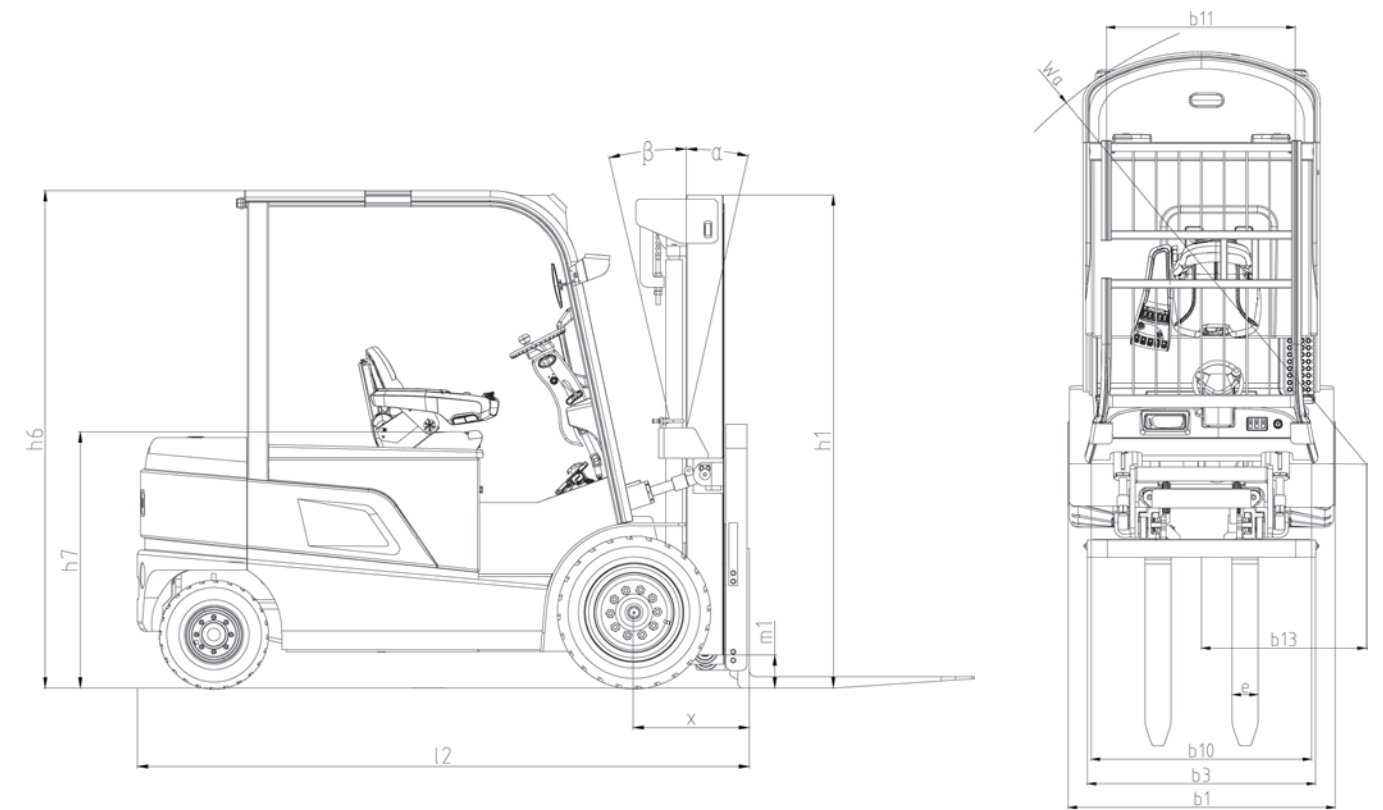

MAST SPECIFICATIONS

Mast Specifications (in)	Fork Height	Free Lift	Collapsed Height	Extended Height	Fwd Tilt	Back Tilt	Capacity 24" LC
							ECB 40, 45, 50
2-Stage Standard Mast	118	5	93	168	6°	8°	10714
	138	5	102	187	6°	8°	10366
	157	5	112	207	6°	8°	10018
	177	5	122	227	6°	6°	9317
2-Stage FFL Mast	118	42	88	168	6°	8°	10714
	138	52	98	187	6°	8°	10366
	157	61	110	207	6°	8°	10018
3-stage FFL Mast	177	42	91	227	6°	6°	9317
	197	49	98	246	6°	6°	8885
	217	56	105	266	6°	6°	8488
	236	61	111	286	6°	6°	8113
	256	68	118	305	6°	6°	7681

*BYD reserves the right to alter and modify the design, features and technical parameters of its products at any given time and without prior notice, as products are subject to continuous development.