

**CLARK**

# WPL40



Max Load Capacity  
4000 lbs.  
(1800 kg)

**CLARK**

# WPL40 Lithium-Ion, Electric Pallet Jack

## Highly Maneuverable for Tight Spaces



The WPL40 gives operators an electric pallet jack designed to work in close-quarters with heavy loads. With the handle in the fully upright position, the WPL40 pin wheels in and out of tight spaces using a smaller, tighter turn-radius. With a 4,000 lb lift capacity, it moves and lifts loads with ease.

# Versatile, Powerful and Dependable

The rugged dependability and flexibility of the CLARK WPL40, with an on-board Lithium Ion Battery, gives you the power to move heavy cargo in confined spaces.

It's the Electric Pallet Jack solution  
you've been looking for!



# WPL40 STANDARD FEATURES & BENEFITS

## ■ ADVANCED ELECTRICAL COMPONENTRY

The water-resistant connectors and shrouded wiring harness supply power reliably to key components. The WPL40 system includes a key switch, emergency power disconnect and on-board dock for Easy Exchange Battery.

## ■ AC MOTOR / CONTROL DELIVERS PRODUCTIVITY

The Lithium-Ion 48-Volt AC provides the same power-output all the way through the charge cycle — giving the operator the same power during the first 10% of the charge as the last 10% as well as surpassing the truck charge power from similar lead-acid batteries. The WPL40's Lithium-Ion power delivers even more:

- Travel speed remains constant relative to the throttle position regardless of load
- A neutral braking system delivers predictable performance
- This well-designed system includes separately fused power control circuits (with quick disconnect EPD power cut-off), hour-meter/battery discharge indicator and a combination gauge and lift lock out-complete



## ■ STRAIGHTFORWARD SERVICEABILITY

The removable covers and the modular design of the WPL40's components, provides for easy maintenance with simple hand tools. And the two-piece drive wheel reduces complexity of tire changes.

## ■ OPTIMIZED GEAR TECHNOLOGY

The state-of-the-art optimized gear technology supplies advantages such as low noise level, high efficiency, and high performance. This technology extends through other componentry which are:

- A horizontal drive motor mounted behind the gear housing provides increased component life
- The oil-bathed, hypoid bevel gear drive train, with tapered roller bearings, easily transfers power to the axle for smooth operation

## ■ LIFTING MECHANISM AND UNDERCARRIAGE MAINTENANCE

The fully adjustable pull rods and torsion bar extends the WPL40 operating life in delivery truck and dock use applications. The WPL40 goes further with easily accessible grease points for easier maintenance.

# WPL40 STANDARD FEATURES & BENEFITS



## ■ HYDRAULIC SYSTEM

The permanent magnet DC pump and chrome plated cylinder provides for smooth and efficient lifting, as well as greater durability.

## ■ EASY PALLET ENTRY / EXIT

The WPL40's fork construction and pallet entry slide system, which allows a lifting of the forks up-and-over the bottom board, provides easy pallet access. The forks, at 27" OAW x 46.0 OAL, can achieve a maximum elevation of over 7.5". Shaped at the load wheel housing, pallet entry and exit can occur without the need for wearable rollers.

## ■ BRAKE DESIGN

The electromagnetic brake, mounted on the motor armature shaft, multiplies the braking power through the transmission and provides good stopping power when the handle is upright or lowered beyond the operating range. Additionally, the top-mounted brake design:

- Keeps the braking mechanism clear from dirt and debris
- Automatically engages the parking brake when the truck stops and the handle is released
- Features an anti-roll back and neutral braking system for improved safety in operation



## ■ EASE-OF-USE ERGONOMIC STEER/CONTROL HANDLE

With travel, lift and lower functions all located in an ergonomic operator handle, operators access all controls without having to lift a hand from the handle. Additionally, the WPL40 control-handle includes:

- A solid steel tubing arm and handle meant to outlast cast aluminum or plastic designs
- Angle grips allowing easy operation with either hand
- A reversing switch, thumb control and horn — all standard
- The low-mounted tiller arm supports minimum steering effort for greater operator comfort
- The gas-assisted spring handle gently returns the handle to a vertical position
- Crawl-speed function enables the operator greater-ease-of-use in tight spaces

# GENERAL DATA & STANDARD DIMENSIONS

## Pallet Specifications

	inches	mm
Type:	Double Faced Wood	
Size:	Length	48
	Width (min-max)	32-48
Bottom Board	Nominal Thickness	0.75
		19

## Available Fork Lengths

Nominal Length		Actual Length	
inches	mm	inches	mm
36	914	33.5	853

## Notes

Performance may vary +5% and -10% due to motor and systems efficiency tolerance. The performance shown represents nominal values which may be obtained under typical operating conditions with a standard machine.

## ANSI/ITSDF and Insurance Classification

Standard truck meets all applicable mandatory requirements of Part III-ANSI/ITSDF B56.1 Safety Standard for Powered Industrial Trucks (latest edition at time of manufacture.)

Users should be aware of, and adhere to, applicable codes and regulations regarding operator training, use, operation and maintenance of powered industrial trucks, including:

- ANSI/ITSDF B56.1
- NFPA 505, fire safety standard for powered industrial trucks - type designations, areas of use, maintenance and operation.
- Occupational Safety and Health Administration (OSHA) regulations that may apply.

Contact your authorized CLARK forklift truck dealer for further information including operator training programs and auxiliary visual and audible warning systems, fire extinguishers, etc., as available for specific user applications and requirements.

Specifications, equipment, technical data, photos and illustrations are based on information at time of printing and are subject to change without notice. Some products may be shown with optional equipment.



## THE CLARK PartsPRO PLUS® SYSTEM

Dependable Parts = Dependable Trucks. This is why CLARK implemented CLARK PartsPRO PLUS®. CLARK PartsPRO Plus is our industry-leading electronic parts and service documentation tool that provides dealers with a quick and accurate method identifying specific parts for every CLARK forklift built since 1961. PartsPRO Plus® ensures the availability of the most current information and has the unique capability to create a part lists specific to your mixed CLARK fleet, making it simple to positively identify and order the correct part(s) from your local CLARK dealer. The right CLARK part - The First Time, Every Time.

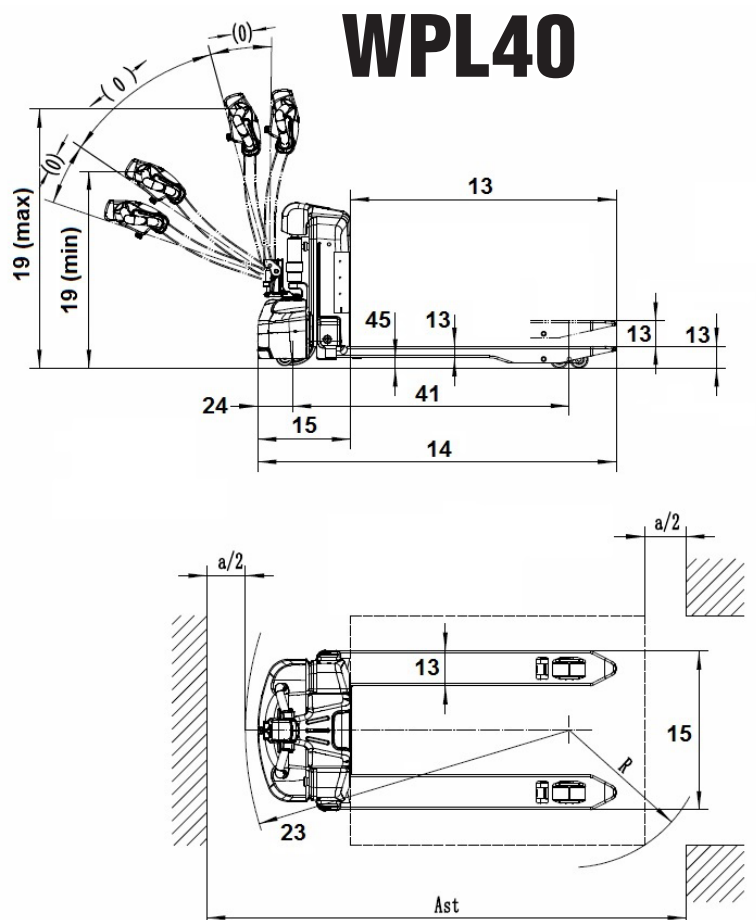

# STANDARD SPECIFICATIONS

General Information	1	Manufacturer		CLARK
	2	Model	Manufacturer's Designation	WPL40
	3	Load Capacity		lbs(kg) 4000 (1800)
	4	Load Center Distance	Fork Face to Load CG	in(mm) 24 (500)
	5	Power Unit	Electric	Elec-48V
	6	Operator Type		Walkie pallet
	7	Tire Type	Drive/Steer - Load	Polyurethane / Polyurethane
	8	Wheels (x=driven)	Front/Rear	1X / 2
Basic Dimensions	13	Fork	Lift height to top of fork	in(mm) 4.5 (115)
			Lowered height at heel/toe	in(mm) 3.2 (80)
			Thickness	in(mm) 2 (50)
			Width	in(mm) 6 (150)
			Usable length <sup>1</sup>	in(mm) 46 (1150)
	14	Overall Length	Overall truck length	in(mm) 63 (1600)
	15	Overall Dimensions	Length to face of forks	in(mm) 15.7 (400)
			Width (OAW - across forks)	in(mm) 27 (685)
	17		Width (across frame)	in(mm) 27.4 (695)
	18		Height to top of frame	in(mm) 27.2 (690)
19	Handle Height	Ground to top of released handle	in(mm) 49.6 (1260)	
		Ground to top of lowered handle	in(mm) 27.5 (700)	
Perfor.	23	Turning Radius		in(mm) 54 (1330)
	24	Head length	Front of frame to center of drive tire	in(mm) 5.9 (150)
Wt.	25	Aisle Width for Pallets 1000 x 1200 crossways (42x48) + 8 in clear		in(mm) 86 (2184)
	26	Aisle Width for Pallets 1000 x 1200 crossways (42x48) + 8 in clear		in(mm) 82 (2083)
Chassis	28	Travel Speed	Loaded / Unloaded	mph(kph) 3.1 (5) / 3.42 (5.5)
	29	Lift Speed	Loaded / Unloaded	fpm(mps) 3.94 (.02) / 4.92 (.025)
	30	Lowering Speeds	Loaded / Unloaded	fpm(mps) 12.76 (.065) / 5.91 (.03)
	31	Max. gradeability laden/unladen		% 6 / 16
	34	Service weight		lbs(kg) 374 (170)
	35	Axle loading, laden front / rear		lbs(kg) 1454 (660) / 2880 (1400)
	36	Axle loading, unladen front / rear		lbs(kg) 286 (130) / 88 (30)
	39	Tires	Number, Front/Casters/Rear (load)	1 / 2 / 2
	40		Tire size, front	in(mm) 8.3 x 2.75 (210 x 70)
			Tire size, rear	in(mm) 2.9 x 3.46 (74 x 88)
Drive Line			Tire size, stability caster	in(mm) 2.9 x 1.18 (74 x 30)
	41	Wheelbase		in(mm) 47 (1200)
	45	Ground clearance	Center of Wheelbase	in(mm) 1.18 (30)
	46	Service brake	Type	Electromagnetic
	47	Parking brake	Type	Automatic
		Steering	Type	Mechanical (pivot arm)
	48	Battery	Type	Lithium Ion
			Battery AH (max)	AH 30
			Battery weight	lbs(kg) 31 (14)
	49		Drive motor control	DC
Speed control			Infinitely variable	

Notes: 1 For 48" X 27" Nominal fork, other fork lengths and widths available, see general data.  
2 Specifications shown for small/large battery compartment models.



# CLARK: The Innovative and Durable Solution

The design, development, and manufacturing capabilities of CLARK, in combination with an unparalleled focus on customer support, a drive to understand fully each customer's needs in order to then supply the right solution, reflect the key essence of what is CLARK.

With over one million CLARK lift trucks sold around the world, each is a testament to the CLARK time-tested process of designing durable trucks with precise features that meet, if not exceed, the material handling needs of our customers. Our full range of dependable products – from pallet jacks to electric narrow aisle order selectors and up to our big 18,000lb capacity lift trucks – assures end-users CLARK has the solutions for their day-to-day needs.



These solutions built from industry innovations, from the nested I-Beam to a self-activating parking brake to new on-board diagnostics, began the same way: with the needs of our customers foremost in mind. By focusing on how we can improve our customers' material handling processes, we can assure our customers a lift truck designed to be the right solution for their needs.

When you bring it all together – an extensive research and development process, state-of-the-art manufacturing capabilities, and a superior dealership network – you have a company dedicated to delivering leading edge products for both today and far into the future. More reasons why CLARK is Built to Last®.

"CLARK, TOTALIFT, Powrworker, PartsPRO Plus, and Built to Last are registered in the U.S Patent and Trademark office. The "Hot Yellow Green" also known as "CLARK Green" is a trademark registered in the U.S Patent and Trademark office."



59-894-2071

**CLARK MATERIAL HANDLING COMPANY**  
North American Headquarters  
700 Enterprise Drive • Lexington, KY 40510  
866-252-5275 • [www.clarkmhc.com](http://www.clarkmhc.com)

**WPL40**  
59-894-2071 Printed in USA OTP0820500  
© 2021 CLARK Material Handling Company